

# The British Sundial Society



## BULLETIN

VOLUME 15 (i)

MARCH 2003



*Front Cover: Vertical south dial, Charlcote Park, Warwickshire (Photo: P. Swann)*

*Back Cover: Kratzer's Dial, St. Mary's Church, Oxford, after Loggan (Drawing from R. T. Gunther's 'Early Science in Oxford' 1923)*

# VOLUME 15 (i) - MARCH 2003

## CONTENTS

2. EDITORIAL
3. JOHN CONSTABLE'S RAINBOWS OVER SALISBURY CATHEDRAL AND STONEHENGE -  
*David M. Colchester*
6. SOME 18TH CENTURY DIALMAKERS IN THE GROCERS' COMPANY - *John Davis*
14. BOOK REVIEW
15. READERS' LETTERS
17. MORE SUNDIALS ON THE CENTROVALLI LINE - *Gerald Stancey*
20. THE MARLOW DIAL
20. A BRIEF HISTORY OF THE BRITISH SUNDIAL SOCIETY - *David Young*
24. DIAL DEALINGS 2002 - *Mike Cowham*
28. NOTES FROM THE EDITOR
29. TWO FURTHER CHINA DIALS - *A.O. Wood*
30. A MERIDIAN LINE IN PALERMO CATHEDRAL - *Margaret Stanier*
32. THE WHIMSICAL ORIGIN OF DAYLIGHT SAVING - *Chris Parsons*
33. TO ESTIMATE THE DECLINATION OF A DIAL - *John Foad*
35. THE SUNDIALS AT THE SKALNATE PLESO OBSERVATORY, IN POPRAD (SLOVAK  
REPUBLIC), AND IN OTZENHAUSEN (GERMANY) - *E.Th. Theodossiou, P.G. Marchos &  
V.N. Manimanis*
37. FROM WILLIAM LEYBOURN, 1700
40. THE DIALS AT ST MARY'S, ELMLEY CASTLE, WORCESTERSHIRE - *A. O. Wood*
43. THE RT. HON. THE EARL OF PERTH P.C. (1907-2002)

# BULLETIN

OF THE BRITISH SUNDIAL SOCIETY

ISSN 0958-4315

VOLUME 15 (i) - MARCH 2003

---

## EDITORIAL

This issue introduces readers to some lesser-known corners of Europe: Sicily, Slovakia and the Swiss-Italy frontier. It is rewarding to find sundials or meridian lines in out-of-the-way or unexpected places. During this summer's holiday season we may expect some further exotic sightings; there is no need to ask Bulletin readers to be on the lookout for dials, with cameras at the ready; they always are.

Within the next few weeks we expect the publication of Jill Wilson's long-awaited work: 'Biographical Index of Sundial Makers from early times to 1924'. This thorough and scholarly work should be of great help to all those of us who have an interest in the history of dialling. Even on a humble level, it will give us the answer to many questions about dating dials from maker's names, and identifying fakes in junk shops.

# JOHN CONSTABLE'S RAINBOWS OVER SALISBURY CATHEDRAL AND STONEHENGE

DAVID M. COLCHESTER

## INTRODUCTION

The sun traverses the sky in a regular and predictable way and sundials keep track of time by monitoring this movement from the shadows it casts. Rainbows also have a definite spatial relationship to the sun and their position and orientation too, will also indicate time. Thus a photograph or painting depicting shadows, a rainbow or the sun will capture a specific moment in time. By analyzing their geometric relationships to fixed features in a scene, whose size and location are known, the date and time of day captured in the scene may sometimes be determined. In such an analysis the principles and methods used in sundial calculations play a key part. Incidentally the position and 'age' of the moon can also fix the time of a scene.

Because of the precise draftsmanship in many of the paintings and sketches by the artist John Constable it is possible for them to be subjected to geometrical analysis. Constable is also noted for his accurate and masterly rendering of skies and atmospheric optical phenomena in his paintings, a number of which contain rainbows.

## A RAINBOW OVER SALISBURY CATHEDRAL

In July 1829 Constable started work on a painting of Salisbury Cathedral titled *Salisbury Cathedral From The Meadows*. In this famous painting, reproduced in many books, (for example Rosenthal, 1987 figure 183) he painted a rainbow arching over the steeple. On page 191 of this book the author states that "Constable knew the physics of rainbows, and Paul Schweizer has shown the Salisbury rainbow to be optically impossible and therefore deliberately inserted". Although the presence of a rainbow may not have been his initial intention when the idea for the painting was conceived, it will be proved that it is physically possible for a rainbow to occur in the position in which it is painted. Also, it is extremely likely that Constable saw the rainbow from where he painted the picture. The presence of the rainbow is also consistent with prevailing meteorological conditions depicted in the painting. In proving this, the date and time of the scene depicted in the painting is also determined. Any symbolic significance that may be attributed to the presence of the rainbow is not discussed.

First it is necessary to determine the precise location where Constable painted his picture. Inspection of the painting

shows that the Cathedral is viewed from a roughly north west direction. Parts of Ordnance Survey maps 1:10,000 and 1:1250 showing the cathedral and reproduced as Fig. 11/4 in the Ministry Of *Defense Manual Of Map Reading And Land Navigation* show the axis of the cathedral to be aligned precisely east-west and the sides of the square base of the steeple face the four cardinal points. In the painting the top of the steeple is displaced slightly to the right of the NW corner of its square base placing the view point a few degrees west of NW.

The line of sight to the steeple intersects the line joining the point where the roof gable meets the north wall of the north transept and the point where the gable over the nave meets the west wall in the ratio 47:53 (a:b in Figure 1). When this geometric relationship is plotted on the 1:1250 map it gives a geographic bearing of  $300^\circ$ . If this bearing is now plotted on the 1:10,000 map it is found to pass close to the junction of the River Avon with the River Nadder and hence identifies the two rivers whose confluence appears in the foreground of the painting. (See Fig.2) From the map this junction is 350 metres at a bearing of  $299^\circ$  from the cathedral spire. At this distance the spire, which is 123 metres (404 feet) high will subtend an angle of  $19.4^\circ$  ( $\arctan 123/350$ ). With this established it is now possible to calculate other angular distances in the painting.

For a rainbow to form high in the sky a veil of raindrops has to be illuminated by the sun low in the sky and behind the observer. The sky in the painting is filled with threatening rain clouds and there is a heavy shower to the west of the nave indicating plenty of rain in the air. That the sun is low in the north western sky is indicated by the direction of the shadow of the fence post in the left foreground and the less obvious shadow cast by the northwest turret obliquely across the roof of the nave. The highlighting of the west front of the cathedral in a golden glow is also indicative of a low sun in the western sky.

Primary rainbows always subtend an angle of 42 degrees with the eye so for a rainbow to have the correct radius of curvature in the painting its radius has to be  $42/19.4$  or 2.17 times that of the spire height. This ratio will hold only for distances 350 metres from the spire. The intersection of perpendicular bisectors (c and d in Figure 1) of chords drawn on the rainbow will locate its center and allow its radius to be measured. The ratio of the measured rainbow

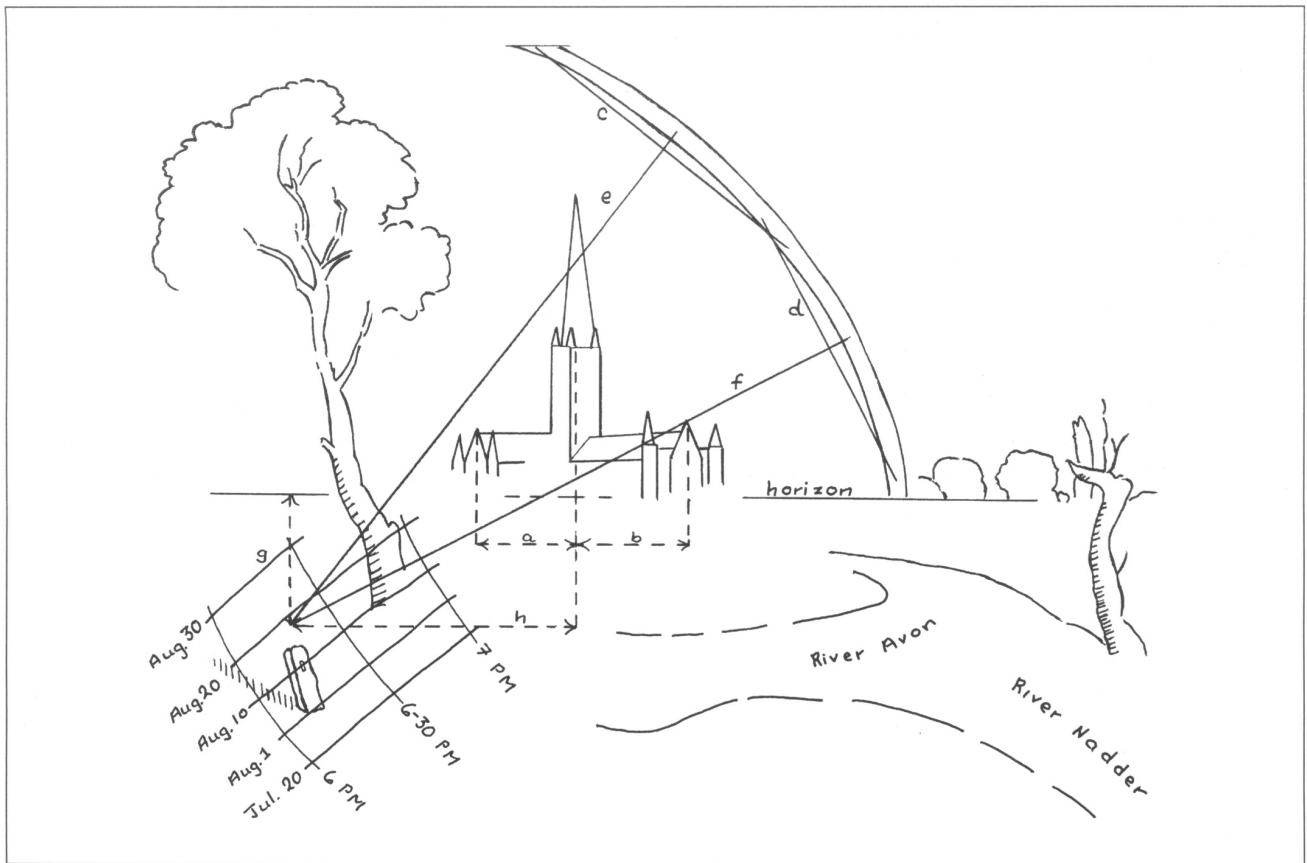

Fig.1. Outline sketch of John Constable's painting "Salisbury Cathedral from the Meadows" showing the dimensions referred to in the text. The day/time grid shows where the centre of the rainbow would be for a given date and time

radius to that of the measured spire height is 2.2, remarkably close to the theoretical value.

The rainbow's center defines the position of the antisolar point. This is a point directly opposite the sun from the observer's head. The angular distance from the cathedral spire ( $h$  in Figure 1) and its depression below the horizon ( $g$  in Figure 1) can be measured using the methods already described. From this the azimuth and altitude of the sun can be determined. The angular distance of the antisolar point below the horizon is  $8.5^\circ$  and its angular distance east of the cathedral spire is  $19^\circ$ . Since the bearing of the spire from the point of observation is  $119^\circ$  the azimuth of the antisolar point is  $100^\circ$ . Thus the sun has an altitude  $8.5^\circ$  and an azimuth of  $280^\circ$ . Calculations with these values of altitude and azimuth using the methods outlined in the appendix fix the moment captured in the painting as 6-09 p.m. sundial time or 6-19 p.m. standard time on the 19th of August.

#### CONSTABLE AND STONEHENGE

John Constable visited Stonehenge on July 15 1820 and made a sketch of the monument (Hawes, 1975 plate 2). Some 15 years or so later he used this sketch as a template for several watercolour paintings to which he added rainbows. Figure 3 is an outline tracing of his initial sketch

with the various stones numbered according to the map given in Richards (1991 fig.47 p.56). By identifying stone alignments along sight lines visible in the sketch with this map the position where Constable made his sketch can be located. This was found to be 7.5 metres south of the southern end of stone 14. The azimuth of the sun can be found by plotting on the map the direction of the shadow cast by the human figure sitting on stone 12 on to stone 11. This is found to be  $275^\circ$  and by calculation the sun's altitude is  $24^\circ$  at 5-12 p.m. sundial time or 5-24 p.m. standard time. Coincidentally the next figure in the book (Richards 1991, figure 48 p.57), which is an oblique aerial photograph of the monument, the stones throw shadows in exactly the same direction! In Figure 3 a primary rainbow is drawn in the position in which it should be under these conditions, as well as the rainbow he has actually drawn in his watercolour of 1836 (Rosenthal 1987 figure 159). The theoretically correct rainbow is further to the right and much lower in the sky. Because of the way in which Constable rendered his rainbow in this painting it is not possible to determine accurately the length of its radius or the position of its center. Hence a calculation of date and time depicted by the rainbow cannot be made.

#### DISCUSSION AND CONCLUSIONS

From the analysis of the placement of the rainbow in



Fig.2. Black-and-white version of coloured postcard 'Salisbury Cathedral from the Meadows' From National Gallery, London, (Card sold to support the National Gallery).

Constable's Stonehenge painting, which was not present when he visited the monument, it is reasonable to conclude that the extent of his knowledge of rainbow theory was not sufficient to allow him to add rainbows to his compositions in their exact size and position. Because the Salisbury Cathedral rainbow does have a theoretically correct size, it

seems highly likely that Constable did indeed see the rainbow from the point where he painted the picture.

It is possible to see a rainbow arch over the steeple for some weeks from the position where the painting was made. On Figure 1 a grid has been drawn showing where the center of the rainbow would be at various dates and standard times. It can be seen that even in late July it is possible for a rainbow to arch over the Cathedral spire.

One may imagine that towards the end of his stay at Salisbury John Constable noticed one late afternoon heavy cumulus clouds forming. So he hurried to the spot from which he had previously painted his picture, to view once more the scene now familiar to him, to catch yet again the play of light. A chance shower and the appearance of an accompanying rainbow gave to his project an extra symbolic significance. It would be with buoyant heart that he would turn back over the little bridge to trudge quickly back through the field past the west front of the Cathedral, hoping to dodge the showers, to Archdeacon Fisher's residence to dress in time for dinner.

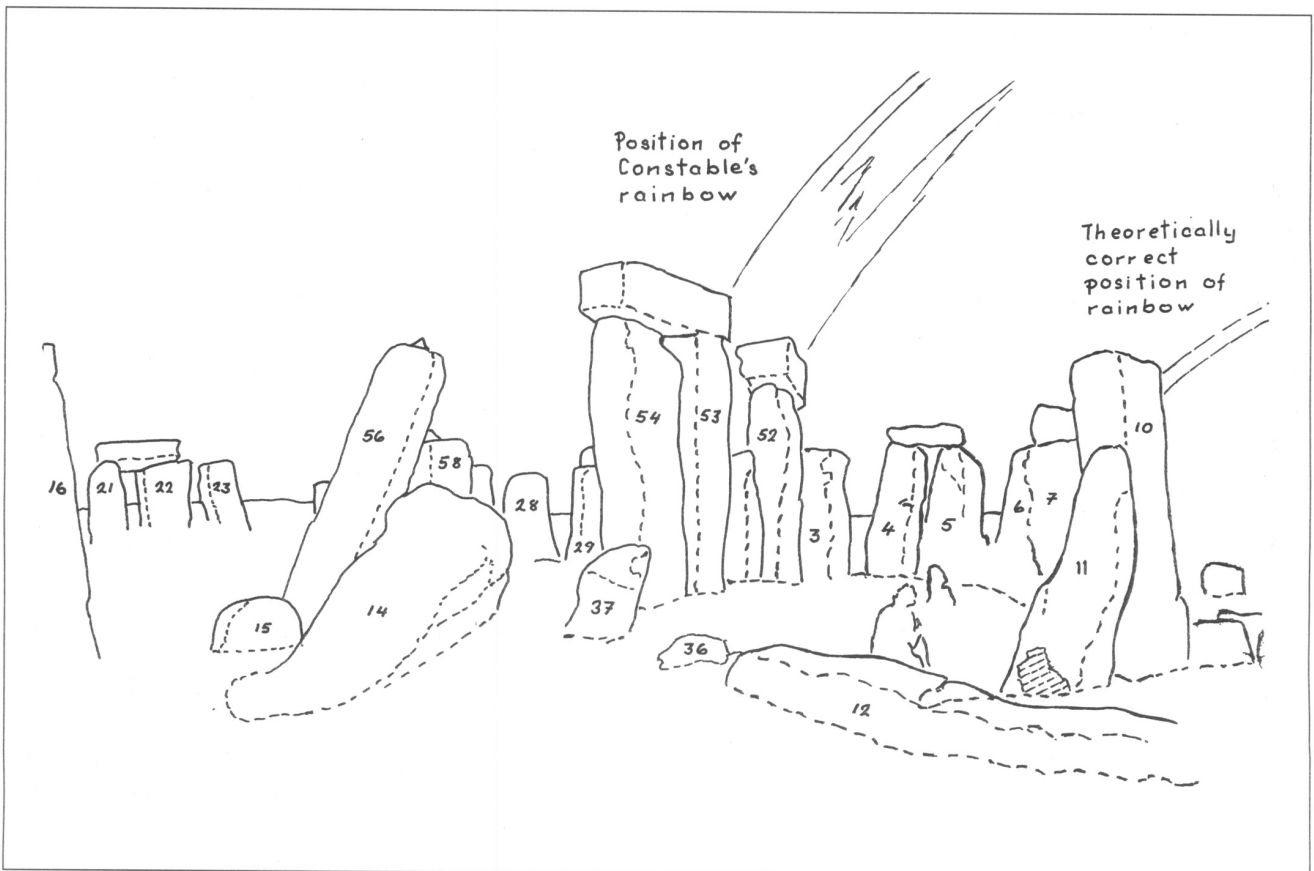

Fig.3. Outline sketch of John Constable's field drawing of Stonehenge made on July 15 1820, on which are superimposed two rainbows. One is in the theoretically correct position, and the other where Constable placed it in a 1835 watercolour copy.

## REFERENCES

- F. W. Cousins: *Sundials: A Simplified Approach by Means of the Equatorial Dial*, Baker, London. (1969).  
L. Hawes: *Constable's Stonehenge*, London.  
Ministry of Defense (UK): Fig 11/4, *Manual Of Map Reading And Land Navigation*, HMSO, London. (1988).  
Michael Rosenthal: *Constable*, Thames and Hudson, London. (1987).  
Julian Richards: *English Heritage Book Of Stonehenge* BCA, London. (1991).

## APPENDIX

The calculation procedure is based on the two standard equations:

$$\sin h = \sin L \cdot \sin d + \cos L \cdot \cos d \cdot \cos t \quad (1)$$

$$\sin z = \frac{\cos d \cdot \sin t}{\cos h} \quad (2)$$

where: h = the altitude of the sun  
L = latitude  
d = declination of sun  
t = hour angle of the sun  
z = azimuth of the sun

In the calculations the cathedral's latitude and longitude is taken as 51. 1°N and 1.5°W and Stonehenge as 51. 1°N and

1.6°W. Declination and equation of time were taken from the tables in Cousins (1969) p.232-235.

To find date and time, given altitude and azimuth rearrange equation (1) thus:

$$\frac{\cos t = \sin h - \sin L \cdot \sin d}{\cos L \cdot \cos d} \quad (3)$$

Calculate the sun's hour angle for the given altitude using equation 3 and then its azimuth from equation 2. Do the same again for a date about 10 days later. Plot a straight line graph of azimuth versus date and read off the date for the given azimuth. Choose the two dates, which (hopefully) straddle the required date!

To find the altitude and time, given the date and azimuth use equation 1 to calculate an altitude for a given time and equation 2 to calculate the azimuth. Do the same again for a different time. Plot a straight line graph of azimuth versus time and read off the time for the given azimuth.

*Author's address:*

*P.O.Box 1549, Macquarie Centre  
North Ryde, NSW 2113, Australia*

---

# SOME 18th CENTURY DIALMAKERS IN THE GROCERS' COMPANY

JOHN DAVIS

*This article is a version of the paper presented by the author at the 2002 BSS Exeter Conference.*

The Grocers' Company is one of the largest and most ancient of the London liveried guilds and has a long history of supporting mathematical instrument makers<sup>1</sup>. It also has been very lucky in that its records have largely escaped the many catastrophes that London has suffered over the centuries so that more is known of its members than of many of the other guilds. The association of the Grocers' Company with instrument makers goes back to the great Humphrey Cole in the 16th century, and passes through Charles Whitwell and Elias Allen right through to the Troughton dynasty in the 19th century. The traditions and methods of instrument making were passed from master to apprentice over many generations, allowing the development of dial design to be investigated. This paper examines some horizontal dials from four selected London makers who form just part of the "family tree" (Figure 1) of

makers in the Grocers' Company in the first half of the 18th century - arguably the period when the finest horizontal dials were made.

## BENJAMIN SCOTT

The earliest maker to be considered here is Benjamin Scott (fr. 1712, d.1751), who is probably best known for his large globes. He started his apprenticeship under James Anderton and became a freeman of the Grocers' Company in 1712. However, he spent part of his apprenticeship under John Rowley (of orrery fame) in the guild of the Broderers, having been turned over in 1706. Relatively little is known of his early career, working from the Mariner and Globe in the Strand. Sometime around 1733 he was convinced by Peter the Great of Russia to emigrate to the St. Petersburg Academy of Sciences where he produced many instruments and stayed until his death in 1751. As well as some extant portable dials, a superb 520mm diameter double horizontal dial of his, probably dated to around 1715, is in the Paris



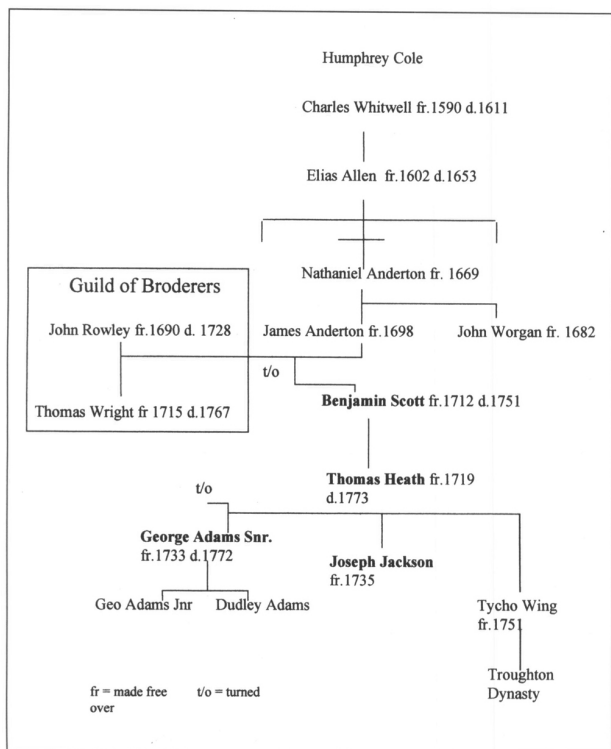

Fig.1. Some selected mathematical instrument makers from the Grocers' Company, showing the master-apprenticeship relationship. The makers shown bold are discussed in the text.



Fig.2. A Benjamin Scott dial at Ham House, Richmond. Note the names of places next to the hour numerals, including "HAM" in the noon gap. Photos: P. Powers.

Musée des Artes et Métiers. Until recently, however, the BSS had no recorded garden dials by Scott in Britain. This lack was corrected in 2001 when it was realised that the high quality dial at Ham House (NT), Richmond, was by him (Fig 2). This approx. 14" diameter dial (undated, probably between 1712 and 1733) has several interesting features to add to the usual furniture of finely engraved compass rose, equation of time (EoT) ring and coat of arms. Firstly, as well as the normal minutes ring outside the main chapter ring, there is a secondary time scale, just inside the numerals, showing fractional hours. This in itself is not unusual, but the divisions go from halves and quarters down to eighths (7.5 minutes) and even sixteenths (3.75 minutes). This must have been very much obsolescent by the beginning of the 18th century: dials in the early 17th century were rarely divided into increments smaller than quarter-hours but by the end of the century the use of minutes had become standard. The use of sixteenth-hours on the Ham House dial is likely to owe more to Scott's training and tradition than to practical timekeeping.

The second interesting feature of the Ham House dial is the names of 32 world-wide locations engraved amongst the numerals in the main chapter ring, with HAM appearing in larger letters in the noon gap. The names are symmetrically placed along the quarter and three-quarter hour lines, but the remains of fine arrows pointing to the minutes ring show the (believed) times of local noon of these places to 1-minute accuracy, implying a longitude known to a quarter of a degree. Dials with place names (called "geographical dials" in this paper) are not uncommon but the details of the

VIII (8:00 pm)		III (4:00 am)
(New Mexico)		
Port Concep <sup>n</sup>		Pekin in China
La Vera Cruz		Borneo Isle
Valad: N. Spain		Siam
Charles Town		Bengal
New York		Fort S <sup>t</sup> George
Boston		Cape Comorin
Berbadoes		Samerchands
Mid of Ter Nova		Ca. Ras Algat
Ca Fare Freez <sup>l</sup> <sup>d</sup>		Isphan
Ca. Spir. Sancto		Babylon
Corva & Flores		Aleppo
S <sup>t</sup> Mich. Isle		Constantinople
Tenerif		Caininiee
Lisbon		Dantzick
Dublin		Paris or Rome
	Dial location (Noon gap)	(London)

Table 1. List of place names on a Grocers' pattern geographical dial, as seen looking at the dial with noon at the bottom. The spellings are taken from the Suffolk Adams dial. The locations shown in parenthesis are sometimes included, depending on the local longitude of the dial.

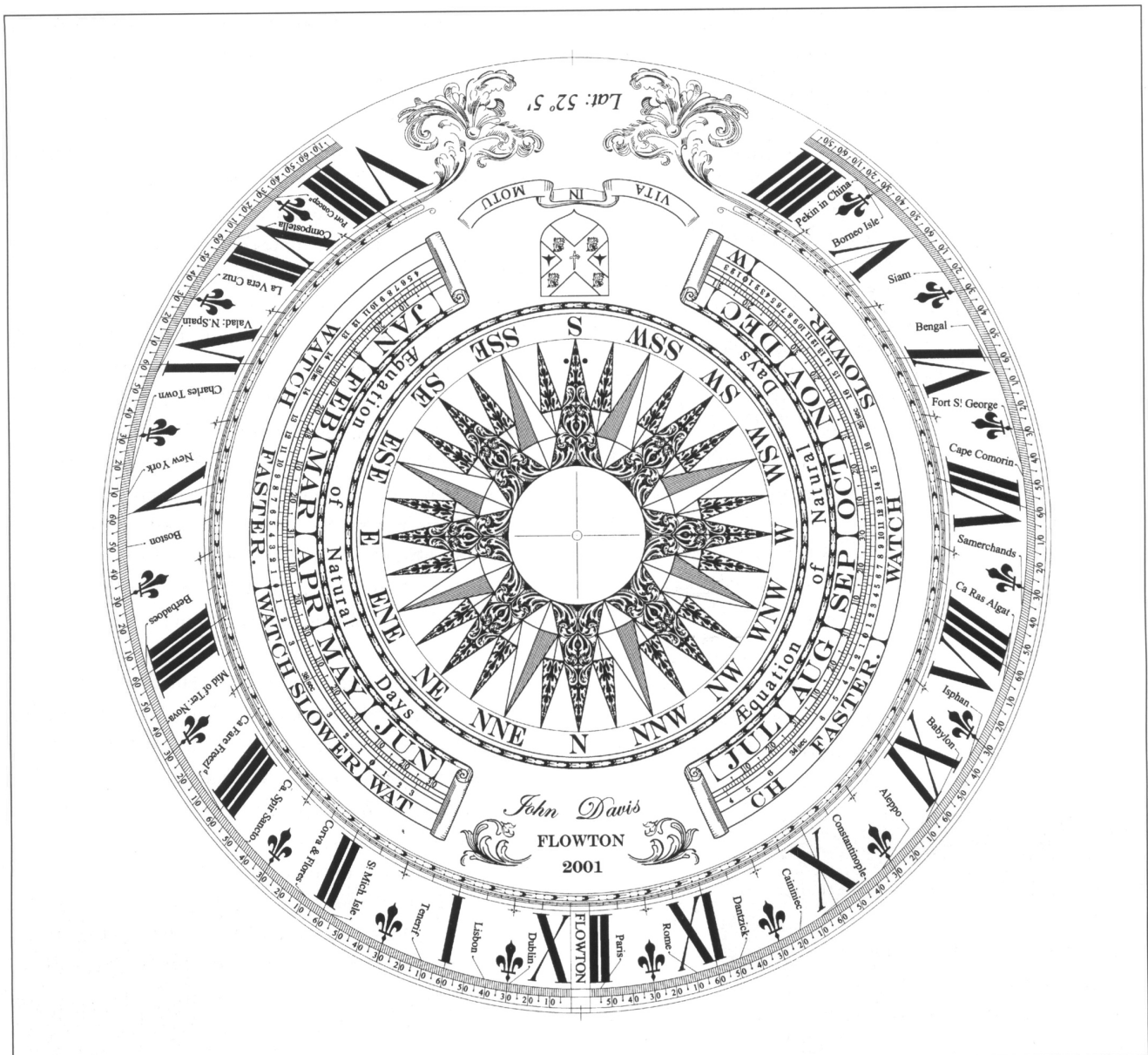

Fig.3. A drawing of a modern version of the Grocers' pattern for geographical dials, using a Gregorian Equation of Time scale and modern longitudes.

layout can follow several forms. For example, Scott's contemporary Thomas Wright<sup>2</sup> (a member of the Broderers' Company and who also served his apprenticeship under John Rowley) made several geographical dials but placed the names in two separate rings inside the chapter ring. The earliest dials known to the author with the place names

positioned amongst the hour numerals are those of Henry Wynne<sup>2</sup> (a member of the Guild of Clockmakers) in the 1680s. It is worth noting that although Elias Allen was originally a member of the Grocers' Company, he was later involved in setting up the guild of the Clockmakers. This may have been the route by which the design became known

to Scott. The names of the locations used on the dial are shown in Table 1 and a generalised view of a Grocers' geographic dial is shown in Fig 3 - both are discussed in more detail below. The Scott double horizontal dial in Paris also has place names in its main chapter ring but they are a

Date of EoT zero	Date of EoT maxima/minima	Value of EoT at maxima/minima
4 April	31 January	14m 49s
6 June	4 May	4m 13s
20 August	16 July	5m 46s
12.5 December	23 October	No value

Table 2. Key dates and the values from the Equation of Time ring on the Thos. Heath dial at Penhurst Place, Kent. The dates are in the Julian calendar. There is no value for 23 October because the maximum is very close to the value of 16 minutes and hence there is no space to engrave the seconds.



*Fig.4. The Thos. Heath geographical dial at Claydon House (NT), Bucks. Photos: P. Powers.*

significantly different set of places and, of course, in French.

All of the dials discussed in this paper have the main hour numerals oriented to be read from the outside of the dial, i.e. from the north. Quality dials in the early 17th century, such as those of Elias Allen, generally had the opposite orientation with the numerals facing inwards, or to the south, as on a clock face. This has the advantage that the tapering Vs fit in well and is particularly suitable for small dials viewed from above. The inwards orientation was still common at the end of the 17th century by which time makers such as Henry Wynne were making some very large (30") dials. Reading a large dial, probably mounted on a relatively tall pedestal, to the nearest minute requires the viewer to position himself at the periphery of the dial and so the outward orientation of the numerals is more natural. This outward orientation seems to have first become common around the beginning of the 18th century.

#### THOMAS HEATH

Benjamin Scott is accredited with five apprentices before he left England. By far the most important of these is Thomas Heath (w. 1720-1753), a prolific maker in his own right but also the master responsible for training many apprentices and thus for much of the later development of

the English scientific instrument industry. Fig 1 shows only some of his apprentices, including his son-in-law Tycho Wing, with whom he later went into partnership ("Heath and Wing") and who trained the first of the Troughtons. Heath is particularly known for his large universal equinoctial ring dials but he also made a number of horizontal dials, several of which are still in-situ. One of these is at Penshurst Place in Kent. As this is only a 12" dial it does not have room for the 32 place names; stylistically, though, it is very close to the Ham House dial. One significant feature of the typical "Æquation of Natural Days" (Equation of Time) ring is that it has additional numbers which give the values of the EoT to the nearest second at three of the four maxima/minima. The values are shown in Table 2, together with the dates of zero EoT. The values at the maxima/minima are far more sensitive to the set of orbital parameters used to calculate the EoT than other measures of the curve, such as the dates of the zero values, and so this feature allows a closer examination of the source of the table (see below).

Thomas Heath did make several geographical dials, some of which are listed in Table 3 (note that their current locations are generally not given for security reasons) and

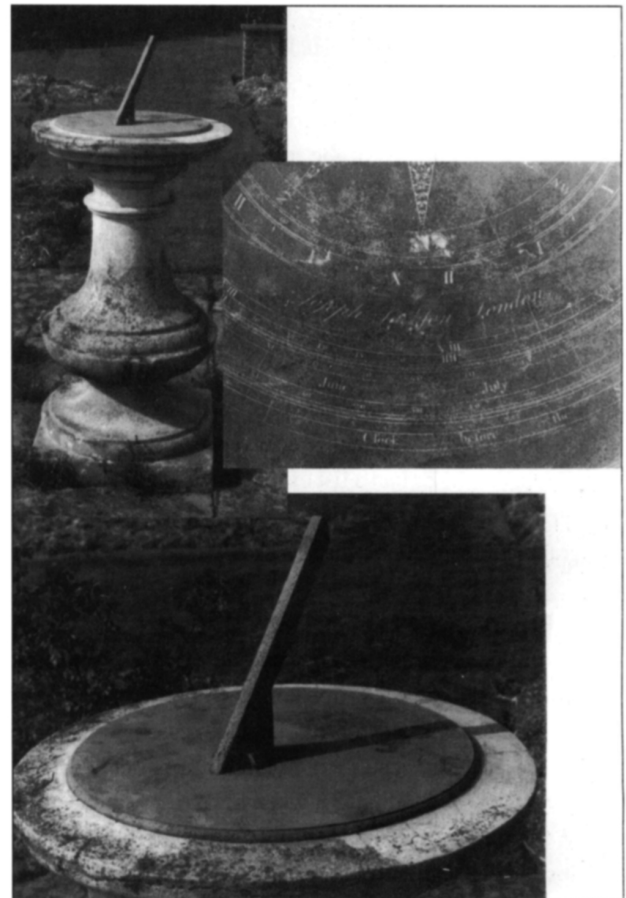

*Fig.5. Three views of a Joseph Jackson dial in Suffolk. Note the double horizontal gnomon and the rather weak engraving.*

Maker	Design Location	Comments
Benjamin Scott	Paris Ham House, Richmond	Double horizontal, different place names
Thomas Heath	Billingbeare House Claydon House Taymouth Cornwall	
Heath & Wing	Cornwall	
George Adams	Suffolk	Pedestal matches Scott's dial
Daniel Harris	Leicestershire	
Cary	Christies	

Table 3: List of some known Grocer's pattern geographic dials. The design locations of some have been concealed for security reasons.

one of which is shown in Fig 4. The pedestal design used for this dial was illustrated by Warrington Hogg<sup>4</sup> supporting a Thos. Wright dial in Kent, so it is clear that masons were working to standard patterns. The facts that the original design location of the Grocers' pattern dials are given in the noon gap and that the dials usually give their design latitude allow some investigations of the accuracy of 18th century mapping of the UK. In general, the design latitudes are within 5-10 arcminutes of the true locations, with a strong tendency for the dial latitude to be to the north of the true value. Heath's geographical dials all follow the pattern of Scott's Ham House dial closely, and also use virtually the same list of 32 place names, although sometimes with minor changes to account for the local longitude of the dial and with some changes in spelling. By comparing the times of noon of several of the places between dials, it is possible to say that Heath was making allowance for the local dial longitude, that is, he had a list of longitudes of his locations, not their Greenwich times of noon. I have yet to locate the geographical sourcebook that he used.

### JOSEPH JACKSON

Joseph Jackson (w. 1735-60) was one of Heath's earliest apprentices, gaining his freedom in 1735<sup>3</sup>. He was a principal supplier of all sorts of mathematical instruments to the Office of Ordnance in the 1740s but it is believed<sup>5</sup> that his prices were rather high so, when his patron at the Office (Lord Montagu) died, he lost this appointment to George Adams (see to right). Examples of Jackson's instruments can be found in the National Maritime Museum, Greenwich, the Science Museum, Kensington, and the Museum of the History of Science, Oxford. A few horizontal dials by Jackson are known, including one at Codrington Hall on

Barbados<sup>6</sup>. The dial shown in Fig 5 was "discovered" in a Suffolk garden a few years ago and is thought to represent a relatively early Jackson dial. It does not follow the pattern of the geographical dials, particularly in that much of the engraving is in lower case and is rather weak compared to the other dials discussed in this paper. Its most interesting feature is that it has the characteristic gnomon of a double horizontal

dial<sup>7</sup> and, although it does not have the stereographic projection of a double horizontal, it does have an azimuth scale which makes use of the vertical style of the gnomon. It also has scales which show the times of sunrise and sunset throughout the year, as well as a standard EoT ring (labelled, in this instance, "Clock Faster/Slower", rather than the more common "Watch Faster/Slower"). The question of why Jackson made a dial like this arises. By this time, the double horizontal dial seems to have been obsolete, with Scott's Paris dial being one of the last professionally made. Certainly, Thomas Heath does not appear to have made one, even as his master-piece. It may be significant that one of Scott's apprentices (confusingly also called Scott, although not thought to be related) was turned over to finish his apprenticeship under Jackson in 1735. Although it is pure conjecture, it is possible that an unused double horizontal gnomon - a valuable and substantial piece of bronze - was lying unused in Scott's workshop when he emigrated to Russia and found its way to Jackson.

Another dial by Jackson is at Wandlebury, Cambs<sup>8</sup>, and this dial (Fig 6) is very much more in the style of the Scott and Heath dials, although it lacks the place names to make it a geographical dial. The engraving is deeper and much more assured than the Suffolk one, most of the lettering is in capitals and the same engraving flourishes and scrolls at the ends of the scales are used. The EoT ring has the letter "S" engraved at the dates of three of the maxima/minima, as on Heath's Penshurst Place dial. The numbers of seconds are placed above the "S" and are difficult to read, but are believed to be the same as the values in Table 2, discussed

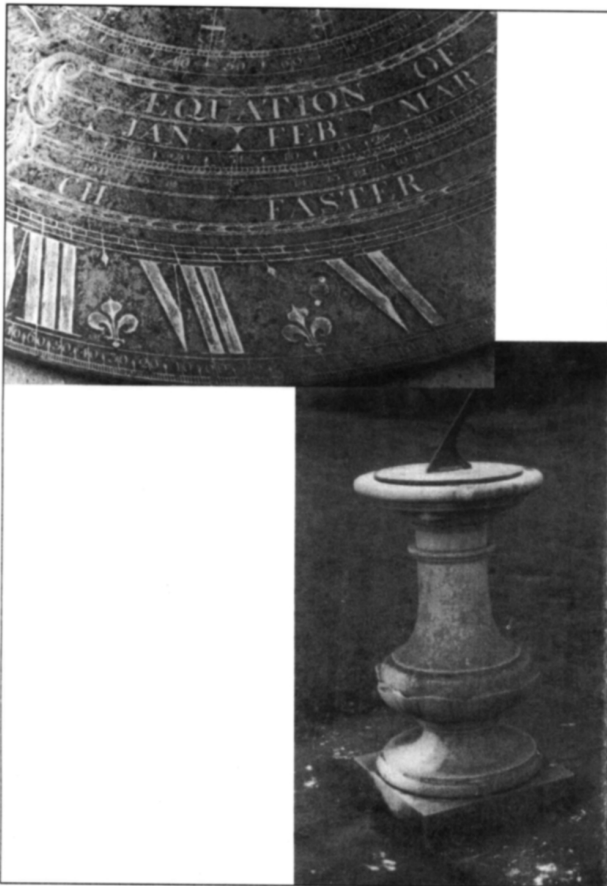
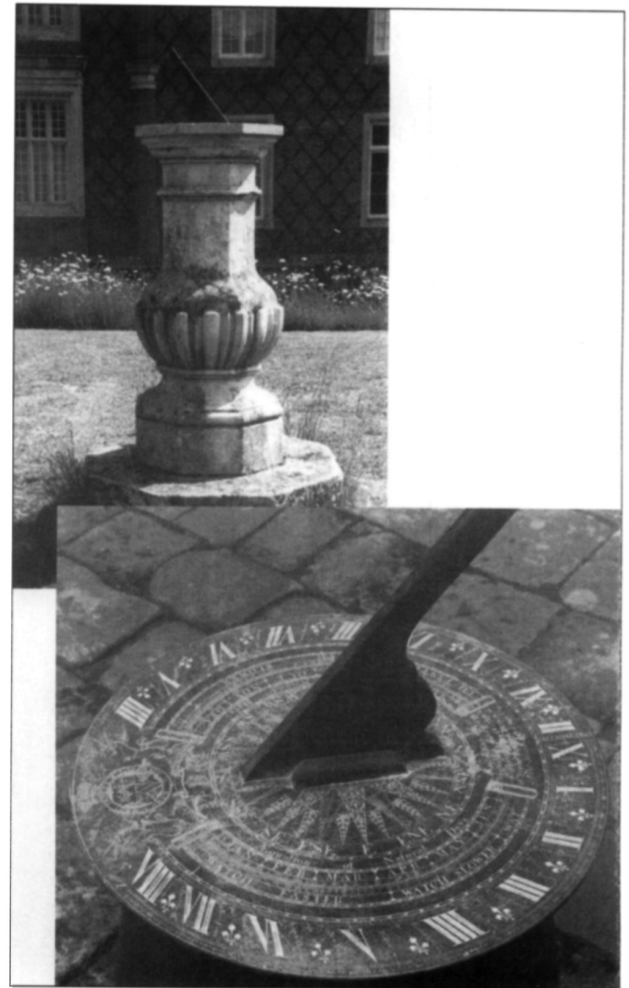

*Fig.6. A Jo. Jackson dial at Wandlebury, Cambs. The Equation of Time ring has an additional "49 S" amongst the minutes at Jan 30, and the compass rose is surrounded by an azimuth scale showing single degrees.*

below. It can also be seen that the pedestals used for the two Jackson dials (Figs 5 and 6) are to the same general pattern.

### GEORGE ADAMS

George Adams Snr. (w.1734 d.1772) started his apprenticeship under James Parker but was turned over to Thomas Heath in 1726. Thus he would have joined Joseph Jackson in Heath's workshop but, being the older man, gained his freedom two years earlier (in 1733). As well as being an excellent craftsman, he was an aggressive businessman<sup>9</sup> and took over Jackson's rôle as supplier of mathematical instruments to the Office of Ordnance: it seems likely that this could have generated bad feeling between the two men. The Adams business became quite large, being continued after his death by his sons George Jnr. and Dudley and, for a while, his widow Ann. When George Jnr. died prematurely in 1796 the business was left to his wife Hannah and was later valued well in excess of £20,000 so that, by today's standards, he would have been a millionaire businessman. Adams sold a full range of mathematical instruments including both portable and garden sundials. Many dials bearing the signature "Geo. Adams London" are known. However, it is not always easy to tell if they come from George Senior's or Junior's period. In either case, it is



*Fig.7. A geographical pattern dial by Geo. Adams in Suffolk. The dial has been lifted off its pedestal and dusted with talc in the lower photograph.*

probable that much of the engraving was done in their workshop by their apprentices or workmen, perhaps with the signature being appended by Adams himself.

There is at least one Adams geographical dial to the "Grocers' pattern" used by Scott and Heath and that is still in its original location in Suffolk. It is a 16½" dial with the signature "Made by GEO. ADAMS Instrument Maker to His Majestys Office of Ordnance at Tycho Brahes Head Fleet Street LONDON" and is shown in Fig 7. The first thing to note is the pedestal, which is to the same pattern as that at Ham House and has also been seen, with a different dial, in an illustration by Henslow<sup>10</sup>. This may result not only from the fact that the masons were still using the same pattern book(s) but also that the house in Suffolk was owned by the same family as purchased the Ham House dial. Although the Adams dial is undated, as are most of the Grocers' dials, the EoT ring shows it to be pre-1751 calendar reform and hence it is probably by George Snr. Certainly, the general engraving style is virtually indistinguishable from the Jo. Jackson dial at Wandlebury. The Suffolk Adams dial is in good condition and was used

as the basis of drawing up the modern version shown schematically in Fig 3. It is instructive to compare some of the features. Figure 8 shows the section of the main chapter ring for 7:00 - 8:00 pm. Two locations are squeezed into the available space: Compostella and Port Conception. The longitudes for these two places are considerably in error (Compostella by  $12^\circ$  and Port Conception by  $2^\circ$ ) such that the order of the two locations had to be reversed on the modern version. Locations nearer to the Greenwich meridian, such as Lisbon and Dublin, were accurate to within a few arcminutes but even New York was nearly  $2^\circ$  in error. Fig 8 also shows part of the time ring for fractional hours, just inside the chapter ring. Adams has now dispensed with the sixteenth-hour divisions shown by Scott but he has retained the eighth-hour divisions. The

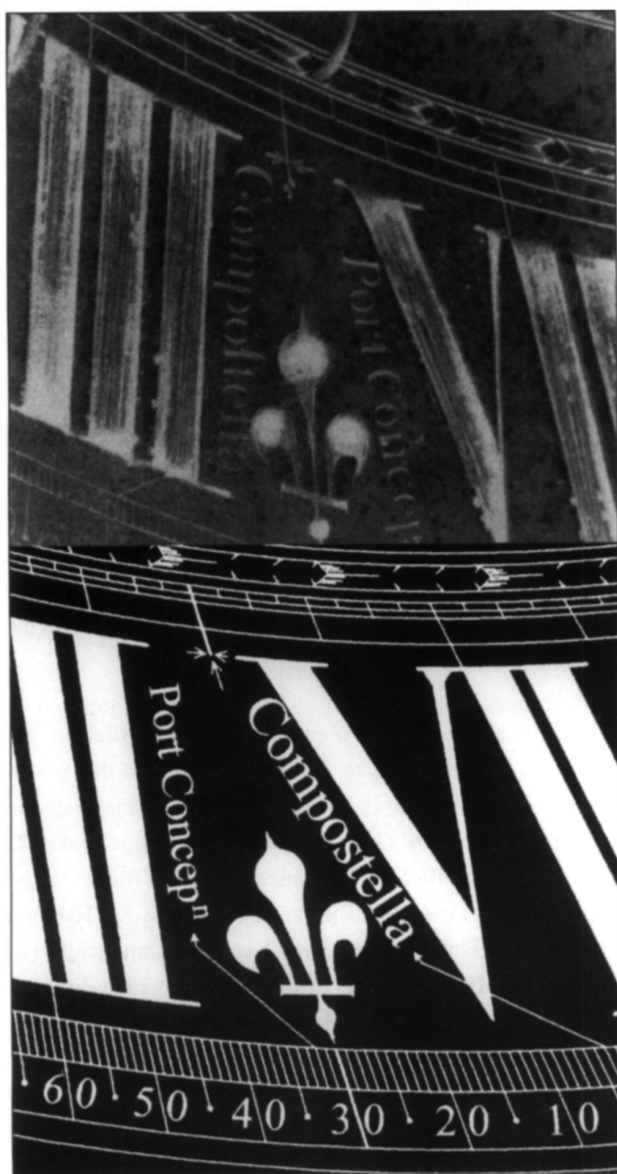

Fig.8. An example of the place names on Grocers' pattern geographical dials. The upper picture is of the Suffolk Adams dial; the lower one is from a modern reconstruction. Note the difference in layout caused by correcting the longitudes.

sophistication of Adams's (or his workman's) engraving can be seen by studying the narrow stroke of the numeral V. On many earlier dials, this would have been formed by a single relatively shallow cut by the graver, with the broad stroke being formed by a number of deeper, parallel cuts. But on the Adams dial, the thin stroke has a very long, gradual taper and small fillets have been added to support the serifs, giving a very elegant effect. Note also how the fleur-de-lys marking the half-hours have been skewed to align with the hour-lines radiating from the origin of the dial which is considerably offset from the centre of the dialplate.

Fig 9 shows a close-up of part of the EoT ring on the Suffolk Adams dial. The extra lettering "13 SEC" indicates that the watch is a maximum of 4min 13 sec slow on May 4. This is clearly using the Julian calendar, whereas the modern equivalent is only 3min 38sec on May 13.5 (Gregorian). The modern values were calculated as averages for the all years of the first half of the 21st century and indicate that not only have the values of the maxima changed, due largely to the changes in the longitude of perihelion, but that the date has moved slightly from the strict 11 day offset between the Julian and Gregorian calendars. Some attempts have been made to match the actual values of the EoT used



Fig.9. An example of the Equation of Time ring on Grocers' pattern dials. The upper picture is of the Suffolk Adams dial; the lower one is from a modern reconstruction. Note the difference in the data of the maximum value due to the calendar change and also the different value due to changes in the longitude of perihelion.

by Adams (and Heath and Jackson) with those published in almanacs and astronomy books of the time. A full analysis will not be given here, but the closest match found is James Atkinson's "Epitome of the Art of Navigation" published in 1735. In turn, it seems that Atkinson was using the same values as those published by John Smart in 1710, based on John Flamsteed's own papers. Thus the Grocers continued to use tables which were up to half a century out of date. The Equation of Natural Days rings shown on dials require translation of published tables, which give the EoT in minutes and seconds on a daily basis, into one where the date, to a fraction of a day, when the EoT is an integer number of minutes is given. This in itself is an interesting technical challenge.

### OTHER GROCERS' PATTERN GEOGRAPHICAL DIALS

The above description of how several generations of dial makers belonging to the Grocers' Company used the same layout of dials leads to the strong impression that a fixed pattern existed and this was passed from master to apprentice during their training. Makers in other guilds also seem to have had a similar arrangement but using different patterns and with a list of place names which varied quite widely in content. Recently, however, I was made aware<sup>11</sup> of a pre-1751 dial in Leicestershire which followed the pattern of Fig 3 exactly, including virtually the same 32 place names (though with slightly different spellings). The maker, Daniel Harris (fr. 1735), was a Freeman of the Joiners' Company. He had served part of his apprenticeship under Thomas Cooke, who was also a member of the Joiners. Cooke, though, had been a business partner to the well-known John Worgan who had been a Grocer and fellow apprentice with Scott's master, James Anderton (see Fig 1). Thus it is possible that the Grocers' pattern for geographical dials reached Harris through this route. Another large (23") horizontal dial by Harris used to be at Polesden Lacey (NT) in Surrey but it was stolen in the 1990s. If it is ever recovered, it will be interesting to compare it to the Grocers' pattern.

I know of one other dial to the general geographic pattern of Fig 3. This was sold by Christies in 1993 and was by Cary of London. There were numerous Carys, the earliest working around 1780 and all members of the guild of Goldsmiths. The dial, though superficially the same pattern, has a significant number of differences to the list of place names and the style of a monogram engraved on it clearly places it around the end of the 18th century. Thus it is apparent that, by this time, the pattern had passed into common currency and was not restricted to the members of the Grocers' Company.



*Fig.10. A dial to the Grocers' geographical pattern but by Daniel Harris, London, a member of the Joiners. The dial is in Leicestershire. Photo: W. Wells.*

Any other sightings of dials to this pattern would be gratefully received.

*Author's address:  
Orchard View,  
Tye Lane, Flowton  
Ipswich IP8 4LD  
john.davis@btinternet.com*

### ABBREVIATIONS

- fr: made free, i.e. finished his apprenticeship and became a Freeman of the Guild.
- t/o: turned over - the term used when an apprentice transferred from one master to another.
- w: worked i.e. the time when a maker was known to be active.
- d: died.
- EoT: equation of time.

### REFERENCES AND NOTES

All the fixed dials mention in this paper are in the BSS Register although the locations of some of them are not made public.

1. J. Brown "Mathematical Instrument-Makers in the Grocers' Company 1688-1800". Science Museum, London, 1979.
2. Thos Wright and Henry Wynne will be the subject of future papers.
3. G. Clifton "Directory of British Scientific Instrument Makers 1550 - 1851". pub. Zwemmer, London, 1995.

4. W. Hogg "The book of old sundials and their mottoes" pub. T N Foulis, London, 1914. Also reprinted (without attribution) in "Sundials and Weathervanes" pub. PIC, Bridport, 1992.
5. J. R. Milburn "The Office of Ordnance and the Instrument-Making Trade in the Mid-Eighteenth Century". *Annals of Science*, 45, pp 221-293, 1988.
6. C. St. J. H. Daniel "Rare treasures" *Clocks* 17/4, p. 28, 1994.
7. C. M. Lowne "The design and characteristics of the double-horizontal sundial" *BSS Bull* 13(iv), pp 138-146.
8. This dial was shown on the cover of *BSS Bull* 14(ii) 2002.
9. J. R. Millburn. "Adams of Fleet Street - instrument makers to King George III" pub. Ashgate, Aldershot, 2000.

10. See *BSS Bulletin* 14(iii) p.125, 2002.
11. W. Wells: Private Communication.

#### ACKNOWLEDGEMENTS

It is a pleasure to acknowledge the many people who supplied photographs, data and information for this study. They include Gloria Clifton, Michael Cowham, Christopher Daniel, Michael Lowne, Patrick Powers, Peter Ransom, Margaret Stanier, Anthony Turner, John Wall, Walter Wells, Harriet Wynter and David Young.

---

## BOOK REVIEW

**Time Lord: Sir Sandford Fleming and the Creation of Standard Time**, by Clark Blaise. Weidenfeld and Nicholson, London, 2000, ISBN 0 297 84136X, pp246, £14,99

Those interested in sundials might have been expected to have heard of Sandford Fleming, if as claimed he created Standard Time. Accordingly the book promises an account of the establishment of the world-wide system, adopted since 1884 with little change, or desire for change, ever since.

The author is a professor of Writing at the University of California. Being a non-specialist does not debar one from writing good book on a technical subject; (one of the best books about the Wright brothers was written by someone outside the field of aviation). But in spite of, or perhaps because of, an impressive bibliography including this year's Somerville lecturer, the book possesses what can only be called 'longeurs' where digressions into the sociology and social history of 'changes in the perception of time' intrude, with numerous allusions to the art and literature of the late 19th and early 20th centuries.

A glance at the index revealed no entry for 'sundial' but sun-dial time is mentioned where appropriate. Sandford Fleming was a Scot who emigrated to Canada, a surveyor and engineer. He was involved in the construction of railways, rising to a senior consultant position on the transcontinental Canadian Pacific Railway. The railways, of course, now presented a transport system where a sufficiently long journey would shift your 'local noon' appreciably if your watch was at all reliable.

Britain in 1848 had, under the guidance of the Astronomer-Royal George Airy, established 'Standard Time' based on the Greenwich Meridian of the day; this was frequently referred to as 'Railway Time'.

It is worth examining the details as to why the relatively early establishment of such time was thought necessary. In practical terms the British traveller would at most be only twenty minutes adrift. If he owned a watch (I don't think ladies owned watches in those days!), re-setting to local time would be trivial, after a glance at a local clock, much as we do today on arrival at our destination airport. Missing appointments and connections are *post hoc* arguments which really didn't apply in the early 1800's.

Blaise, of necessity, has to cover a great deal of railway history and does it well and interestingly, both for American and European railways, pointing out for instance, that the invention of the bogie for carriages led to differences carriage styles and layouts with consequent different attitudes to rail travel. In Britain, railway time, tied as it was to London and hence to the headquarters of many railway companies, was adopted without dissension. In the United States each railway felt free to adopt its own time along its own tracks, the electric telegraph providing the means to do so. St Louis, therefore offered no less than six railway times from amongst the fourteen companies operating there; now the problems of missed connections could be a realistic possibility.

It may seem that the reasons for the early adoption of Standard Time in Britain and persistence in holding on to one's own company time was not necessarily for the benefit



of the passenger. After all, the benefit and convenience of the passenger have not appeared high on the list of railways' desiderata. So much so that in Britain, even in the 19th century Parliament required certain trains to be run for the benefit of the non-first-class passenger. The benefit to the railways of a standard time was a simplification in assessing punctuality, working hours, lost time, and all the other reasons for keeping track of employee wages and costs. In case this seems far-fetched, remember that surviving crew members from the Titanic had their pay stopped from the time *the ship went down*.

In the event, although railways played a large part in Fleming's thinking, it was his persistence in organising conferences of astronomers, diplomats and admirals that led ultimately to the Washington conference of 1884 and the adoption of Greenwich as the prime meridian, in the face of spirited French opposition.

Fleming's own proposals were not adopted; indeed it fell to the Russian diplomat/astronomer, Charles de Struve to 'tidy up' from the adoption of Greenwich and 24 hourly time zones.

For example:

- (a) Longitude to be measured 180 degrees east and west rather than 360 degrees in one direction only

- (b) A 24-hour clock, avoiding the confusion of a.m. and p.m., the original cause of Fleming's crusade.
- (c) The International date line, conveniently in the uninhabited Pacific Ocean and which replaced arbitrary date lines created by the nations which traded in the Far East.

The book therefore serves as a good history of Standard Time but is beset by excursions into art and literature which can only be described as speculative. As a biography it is a shade short in detail. Was Fleming married? What did he get a knighthood for? Why exactly was he dismissed from the Canadian Pacific Railway? The author occasionally lets himself be led on to sentences like 'Light is energy as Einstein eventually showed' and 'the myth of western expansion'.

There is considerable technical and scientific interest here, and the book is well researched, but with such 'padding' as to make the journey through it troublesome.

*Tony Wood,  
Gloucester.*

---

## READERS' LETTERS

### THE CROWAN DIAL

The two articles in the December Bulletin about the important discovery of the Crowan dial in Cornwall were of considerable interest.

I feel an alternative explanation of its delineation should be offered.

Basically, the anticlockwise numeration is as found on vertical (wall mounted) dials and the regular 15 degree spacing would indicate that it is of the same era (medieval) as the well known mass dials ('scratch dials') found on many of England's churches. Such a dial is on the rear cover of the above Bulletin.

The 'secretary hand' of the numerals indicate that it was almost certainly carved by the priest or minister but at any date stretching over a couple of centuries (15th and 16th, roughly) (1). Numerals sometimes occur on mass dials, usually later ones, and a cross at noon is also well known.

There are practically no mass dials in Cornwall. Len Burge found traces of one at Manaccan (2) and that was all. I suspect that the local granite was too hard for 'amateur' carving and a piece of slate, with the dial on, nailed to the wall was Cornwall's form of mass dial. The tradition of carving on slate was then carried on into the many slate sundials seen today on Cornish churches.

The gnomon would have been horizontal and fitted in the hole. The dial would not indicate hours at all accurately but would indicate when a service was due. This would vary throughout the year.

The extension to 4 a.m. is not unknown but would only be space filling. Normally vertical dials work only from 6 a.m. to 6 p.m. and so the alignment of the south wall of St Crewenna would be of interest.

The rarity of the discovery of such a dial perhaps explains some differences of opinion in the interpretation.

Redacted

- (1) Personal communication - Dr B Barker-Benfield,  
Bodleian Library, Oxford  
(2) 'Cornish Church Sundials': L Burge, Truro, 2002

*A.O.Wood*  
*Churchdown, Gloucester*

Redacted

**'LINES OF COINCIDENCE:' A COMMENT**

I do not wish to be a pedantic spoil-sport, but when John Moir writes (Letters, 2002) that " the Sun's declination of 8th May is 16° 55'" I'm afraid that was true just in the year that Waugh's book was published.

For the current year, The Nautical Almanac (HMSO) gives the Sun's declination at noon on 8th May as N 17° 06' . The reason for these tiny changes from year to year is Precession in Declination.

I am also sorry to say that the declination of August 6th this year did not match that of 8th May; it was N 16° 40' . At no time on that day was it 16° 55'.

I have to say that the earlier matching declinations were just simply coincidence. Man proposes, the Heavens dispose.

*C.D.Lack*  
*Northampton*

### A LEADED-IN GNOMON

In his interesting and detailed article on the Dinton Church Sundial (Bulletin. Volume 14 (iv).Decemher 2002.) Christopher Daniel writes "The gnomon, evidently, was either 'free-standing', i.e. separately 'leaded in' to the stonework of the pedestal, (which would seem to be unique, there being no known dial extant having these characteristics).....," I believe there is another example which may be found in the churchyard at Binton, Warwickshire (SR No 3526) where a gnomon sticks out of the top of a short pillar but there is no dial plate. It does not appear that the dial was ever engraved on the upper surface of the stone either. (See photograph).



*A Leaded-in gnomon in St. Peter's Church, Binton, Warwickshire.*

Of all the processes needed to make a dial in the 16th century or even later, brazing might have proved the most difficult for someone in a small village and it is surprising that more examples of 'leaded-in' gnomons have not been found. It is possible that some have been overlooked by those of us who record dials as the joint between gnomon and dial plate is so often obscured by dirt and corrosion. Perhaps we should look more closely at this aspect of old horizontal dials.

At all events, the finding of just one more example lends support to the author's conjecture that the Dinton gnomon "was 'free-standing' and probably separately 'leaded-in' to the pedestal, having been aligned in the meridian first."

*John Lester  
24 Belvidere Road  
Walsall,  
West Midlands, WS1 3AU*

---

## MORE SUNDIALS ON THE CENTROVALLI LINE

### GERALD STANCEY

In a previous article<sup>1</sup> I described the excellent dials that adorn the railway station at Re in Northern Italy, and referred to other dials that can be seen from the train in the same area. At the time I did not know who made them. Now thanks to one of our Italian members, Ing. Enrico Del Favero, I can give the designer, Dott. Arch. Gaicomo Bonzani, the credit that he deserves.

Signor Bonzani has sent me these photographs of some other dials that he has made. They are all in the same area of northern Italy. As Switzerland is our favourite holiday venue there is no doubt that we will visit them on some future holiday.

#### REFERENCE:

1. Stancey, G: 'More Railway Sundials' *Bull.BSS.* 14(i), 42 (2002)

*Author's address:  
22 Peterborough Avenue,  
Oakham, Rutland, LE15 6EB*

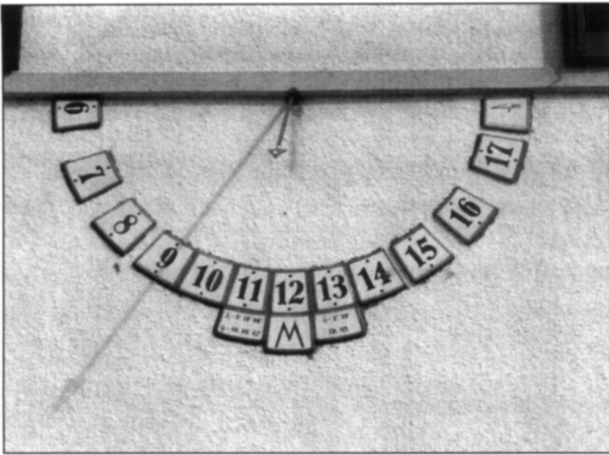

Figure 1, A and B, Domodossola, South wall.

The Sundial at Domodossola station is a direct south facing wall dial: numerals from 6 a.m. to 6 p.m. (6 to 18 hours) are on ceramic tiles. A tile below the '11' gives the longitude  $8^{\circ} 16' 06''$  and latitude  $46^{\circ} 06' 42''$  of the station. The gnomon is a projecting arm ending in a triangular plate with pinhole aperture.

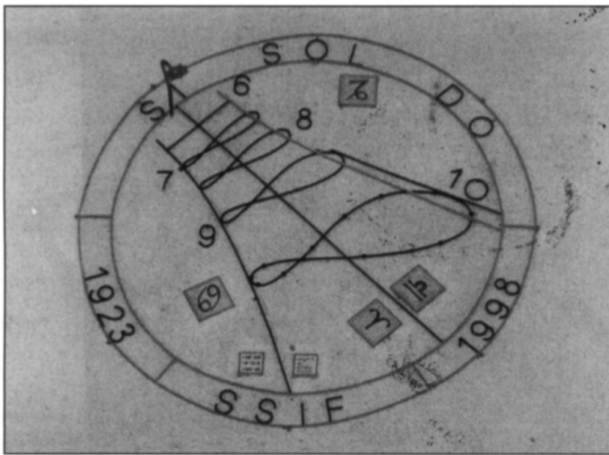

Figure 2, S.Maria Maggiore, East wall.

A series of anemmetas mark the early morning hours from 6 until 10. The sundial commemorates the 75th year of the railway line.



Figure 3 a.

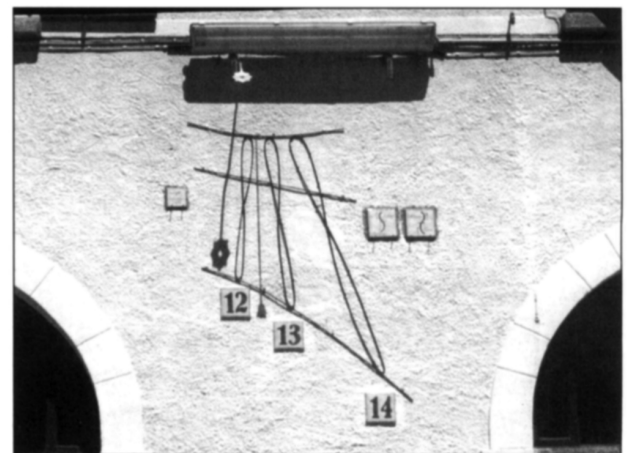
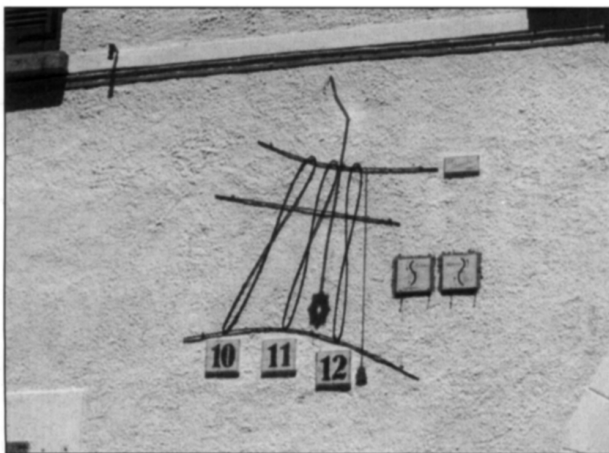

Figure 3, A,B, and C, S. Maria Maggiore, South East wall

A pair of sundials, shown together in A, then separately in B and C, mark the hours until 14 (2 p.m.) by anemmetas lines. The gnomon is a projecting disc with pinhole aperture. The significance of the red thread with bell-weight at 12.30 is obscure. Perhaps it marks the time when the once-a-day train comes through.

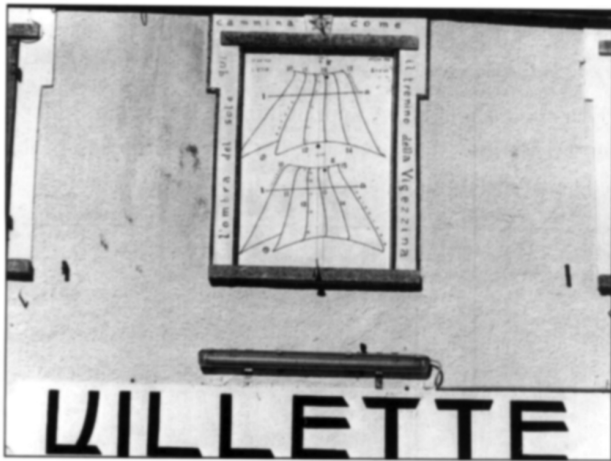

Figure 4a.

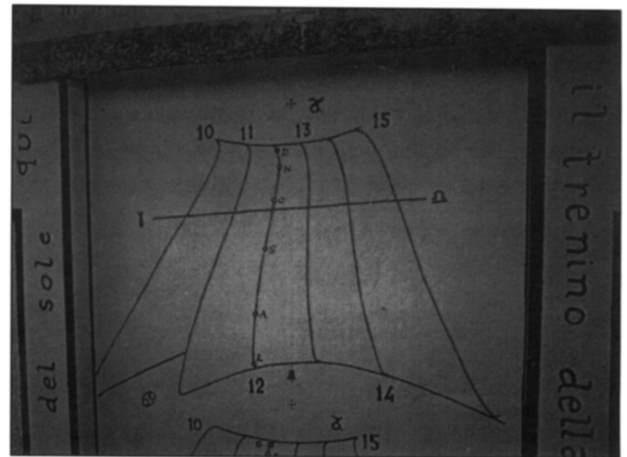

Figure 4b.

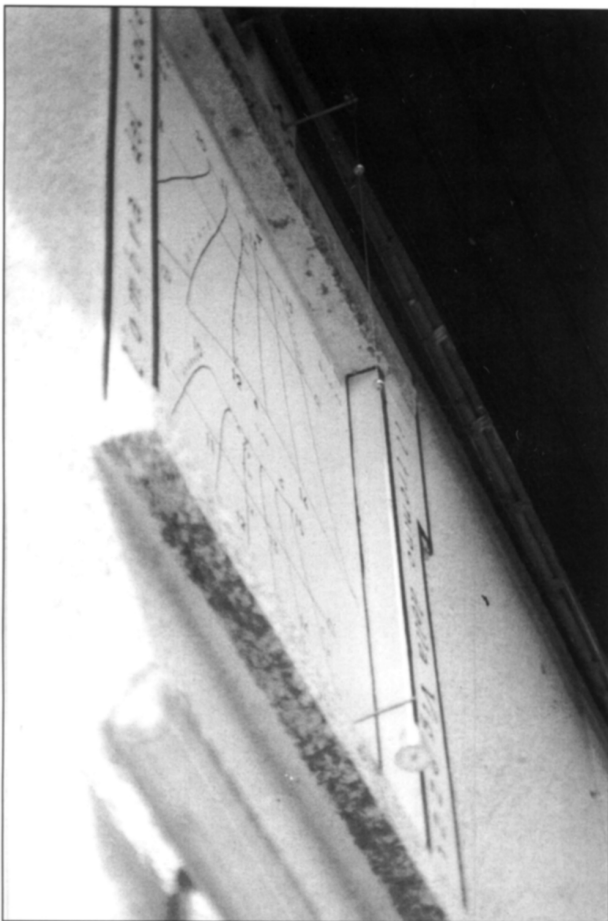

Figure 4c.

Figure 4, A, B and C, Villette, ?South West wall.  
The photos show a pair of dial-faces apparently marking hours from 10 until 15.

The letters along the 12 noon lines presumably mark the months, July to December on upper dial, January to June on lower dial. Fig. 4A shows both dial-faces; Fig.4B shows the upper dial-face in close-up.

The gnomon appears to be a thread suspended from an arm projecting from the centre of a star-pattern above the top dial-face, carrying two (or perhaps three) beads, and weighted at its end by a bell. The beads and bell are visible in Fig.4C, and their shadows are visible in Fig.4A

#### OBITUARY: MR.G.E.HESKETH

Ted passed away last December after a short illness. He was an early member of the Society and regularly attended the Annual Conference until health problems arose in recent years.

By profession Ted was a chemist. After war service in the RAF on radar installations he worked for the government on health and safety issues associated with the nuclear industry.

On retirement he and his wife ran a guest house in the Yorkshire Dales which is where I first met him and where he persuaded me to join the BSS. I will miss our conversations from which I always emerged enlightened and enthused no matter what the subject.

G.P.S.

# THE MARLOW DIAL

The Akeler Sundial in Marlow, in its pleasant quiet garden setting: in the background, handsome wrought-iron gates and Marlow Place, a Grade 1 - listed building.

This photo should have appeared in the December Bulletin in the Marlow Sundial article, but unwise cropping of the edges of the photo removed the garden scene.



*The Akeler Sundial in Marlow.*

---

## A BRIEF HISTORY OF THE BRITISH SUNDIAL SOCIETY

DAVID YOUNG

*[Part 1 of this History, published in Bull. BSS 13 ii, covers the period 1986-1989. Part 2, published in Bull. BSS 14 i, covers the period August 1989-March 1990. The article below covers the period June 1990-April 1991]*

### PART 3

Following the successes of our first AGM and conference at Oxford in March 1990, the society was now officially born, with a constitution and governed by an elected committee called henceforth, the "Council". With new members agreeing to take over responsibilities as Treasurer, Membership Secretary and Dial recording it would leave me with little to do... in theory! In practice it was not quite

like that: Richard and Janet Thorne wanted to delay the take-over of the first two posts for a few months, and Gordon Taylor who had taken over dial recording with the title of "Registrar" wanted to design a new recording form suitable for entry into a data base that he was developing.

All this meant that I continued with the first two jobs for some months and with dial recording for considerably longer - some two years in fact, as we thought it important that the enthusiasm of our team of recorders should not be dampened by a long period of inactivity.

Mike Cowham agreed to act as Meetings Secretary, helping Andrew Somerville with arrangements for our various meetings and with the minutes. Andrew himself was busy with correspondence of all sorts, answering queries from members and from the general public. Following a decision at the conference he was in contact with the Charity Commission and having submitted our constitution was told in a detailed letter that explained that some of our objects were not charitable - and they all had to be in order to be accepted. Andrew was given advice as to how the wording could be changed which meant that he had to go back to the drawing board. He was anxious to make initial preparations for our next conference at Edinburgh and had written for help from our member in Edinburgh, Dr David Gavine with a view to finding places to visit and a place to hold the meeting, possibly The Pollock Halls or Heriot Watt University.

*Andrew Somerville*

Charles Aked was busy with preparing the next issue of the Bulletin - this time with a new format in mind. Although the membership fee had been increased we still had limited finance and both he and I could not find a printer in the Home Counties that could do the job within our budget. However he eventually found a printer in Stratford-upon-Avon (Stratford Repro) that could print the 32-page journal from typed text at a cost of £1.92 each (assuming a print run of 350 copies)

Charles Aked and I drove to Stratford to sort out details and general layout of our new style bulletin. It was there, that after some discussion we chose the shade of yellow for the jacket, that has ever since been the symbolic colour associated with the Society. With tongue in cheek we suggested that they might "like" to distribute them for us; after some initial reluctance they agreed to do this for a small charge providing we supplied the address labels which I was quite happy to do. This was a great relief to the Editor for as the membership increased it was becoming a wearisome job that he was glad to forgo.

In the meantime Jane Walker who had been asked to take over "Education" had been gathering a team to help her. On 3rd June 1990 the group met to commence work on an educational pack for schools that would meet the requirements of the National Curriculum, in the science section of which there were several references to sundials. Amongst others in the team were David Brown, Graham Stapleton, Michael Maltin and David Pawley, all of whom are still active members today. This was the start of a series of meetings that finally resulted in the publication of the book "Make a Sundial" that is still in print today.

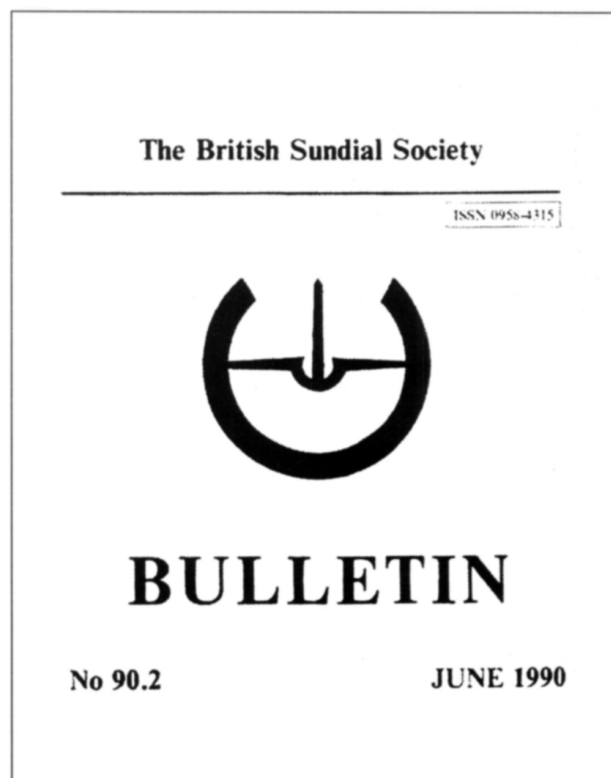

*The first printed Bulletin*

Apart from a brief meeting of the new council at the AGM the first formal meeting of the committee took place on 10th June 1990 at the home of Andrew and Anne Somerville near Manchester. Here the Council ratified Andrew's decision for an Edinburgh conference in 1991; Mike Cowham was prepared to organise the event and

would be able to get help from a local member. Gordon Taylor set out some of his ideas for reorganising the dial recording program using a form more suitable for entry into his database. I reported that we had 29 new members but that so far 40 members had not rejoined and that we had £3,011 in the bank, more than enough for two Bulletin issues with more money still to come from subscriptions. Richard and Janet Thorne said that they would be shortly ready to take over as Treasurer and Membership Secretary. The Editor warned that the first printed bulletin would be late due to difficulty with the printers - one initial problem was that they could not print the Greek alphabet or Signs of the Zodiac!

I had a long letter from Andrew on 21st June and it was arranged that he and Anne would come to London and stay overnight with us. On Monday 25th we had a lengthy talk together on the telephone. The next day, 26th June 1990, Anne telephoned in the evening to say that Andrew had died that afternoon.

It was a heart attack, striking quite suddenly on his way back from posting a letter at a box a few yards down the road. Christopher Daniel, Charles Aked and I had long talks over the telephone and within days I had letters from other members of the new council; the general tenor of these were very well expressed in the letter from Mike Cowham:

*"It was a great shock to me today to learn of the death of Andrew Somerville. He will be sadly missed by Anne, his family and us all. As far as the BSS is concerned his loss will be particularly felt as it was due to his indefatigable efforts that the Society came into being. I believe that we should now all work particularly hard to keep his society running .....The Society must go on and become Andrew's most permanent memorial."*

There were calls for an urgent meeting of the council and I was asked to make the arrangements and act as a temporary secretary until a meeting could take place. However in spite of Gordon Taylor offering his home as a venue for the meeting it was not possible to find a date suitable in July or August because of members' holiday arrangements and we felt that it was important that we had a full attendance. In any case I was in a unique position to know that Andrew's careful planning had ensured that the Society would coast along for some time. I had just travelled to Plymouth to see the Thornes and had handed over the jobs as Treasurer and Membership Secretary to them; Anne Somerville would pass on correspondence to me or deal with it herself and Mike was dealing with the arrangements for Edinburgh. Meanwhile Charles who had all this time been working to

get the new edition of the Bulletin out, had to scrap the first page for an announcement of Andrew's death to the membership at large. It finally came out in mid July, dated June 1990; it consisted of 32 pages proudly displaying Christopher's newly designed symbol for the first time.

In August Charles Aked telephoned me to ask me if I would accept nomination as Secretary of the Society and suggested that he would like to nominate Christopher Daniel as Chairman (Andrew had occupied both posts). I was very happy to second that proposal but a little wary about my nomination as Secretary until Charles convinced me that I was probably the only person with the time to do the job. In the event, at the meeting held in November 1990 at Crowthorne, both Christopher and myself were duly elected with a unanimous vote. All members were able to report good progress in their various tasks. The membership had continued to increase and now stood at 314 and the Treasurer was able to report that we were still solvent and all bills had been paid. Charles wanted to make the Bulletin a quarterly publication (a plea that he was to repeat periodically for a number of years!) but this was not agreed, strictly for financial reasons. Charles proposed that we should invite the (then) Astronomer Royal, Sir Francis Graham-Smith to become our President and to confirm Lord Perth as our Patron. Both these proposals were carried. In the afternoon Jane Walker had organised a local members meeting where amongst others our member Robert Mills gave an interesting illustrated talk.

For some time I had been receiving increasing numbers of record forms, the majority from three members, Richard Thorne and Neville Rodber from the South West and from an enthusiastic member from Cumbria, Robert Sylvester, later to be well known as our Membership Secretary for many years. This had partly been occasioned by my sending out a trial listing of dials during the summer and another in October 1990 with brief details of about 500 dials received from 19 recorders. In this I had valuable feedback from Robert Sylvester and other recorders which led me to install a database program on my Amstrad word processor enabling me to produce a more comprehensive listing in the following April, this time with twice the number of dials from 26 recorders. At the same time I was able to distribute an additional one with over 400 dials from Scotland which had been painstakingly transcribed from Andrew's records by Anne Somerville.

Our most important event of the year was and is our Annual Conference. A subcommittee chaired by Christopher Daniel to assist Mike Cowham had been set up during the summer and it met regularly, but it was Mike who bore the main responsibility of the operation. Apart from liaising with Dr



David Gavine in Edinburgh and arranging bookings and deposits of the membership he was planning the overall programme and finding speakers. The job was made more complicated because although we had expected fewer members would make the journey to the north (most of our membership was concentrated in the south of England) we were planning a three day conference, with an optional day for a sundial tour. In addition to all this, he was making initial plans for a joint meeting with the Netherlands Zonnewijzerkring in September 1991 to be held in Cambridge.

We were anxious to promote the idea of local meetings and one was arranged at the time of our final Council meeting before Edinburgh, which took place at the Old Observatory at Greenwich. Here we were shown some of the Observatory's sundial collection not normally on view and we were lucky in that our Chairman was able to tell us much more about the exhibits. Later he led us to the planetarium where he gave a most interesting presentation with the accent on the path of the sun.

Anne Somerville who had been co-opted to the Council agreed to organise the sundial tours in Edinburgh. At the end of the month Lilli and I accompanied her to Scotland where we stayed for a few days to try out the intended

routes, and at the same time made a brief visit to the Pollock Halls to check out arrangements there. On our return we visited Jodrell Bank to encourage them in their efforts to make a sundial trail in the grounds; we had already offers from Silas Higgon, Margaret Ta'Bois and George Higgs to donate dials.

The Conference began on Thursday 3rd April 1991 and on this first day we had the tour around the outskirts of the city guided by Anne Somerville. The conference proper was begun with a welcoming speech by Christopher Daniel and then followed three days of lectures, visits to dials on foot and a most interesting guided tour of The National Museum of Scotland preceded by a talk from its Director, Dr R Anderson. There were lectures by members such as Allan Mills, Gordon Taylor, and George Higgs. The Education Group, headed by Jane Walker, whose book for schools had just been published, gave a presentation including a most interesting talk by David Brown. The highlight of the conference was the first Andrew Somerville Memorial Lecture given by our Chairman, on English Polyhedral Dials. This was followed by the Society's AGM at which thanks were given to Mike and Val Cowham for all their hard work to make this second conference such a great success.

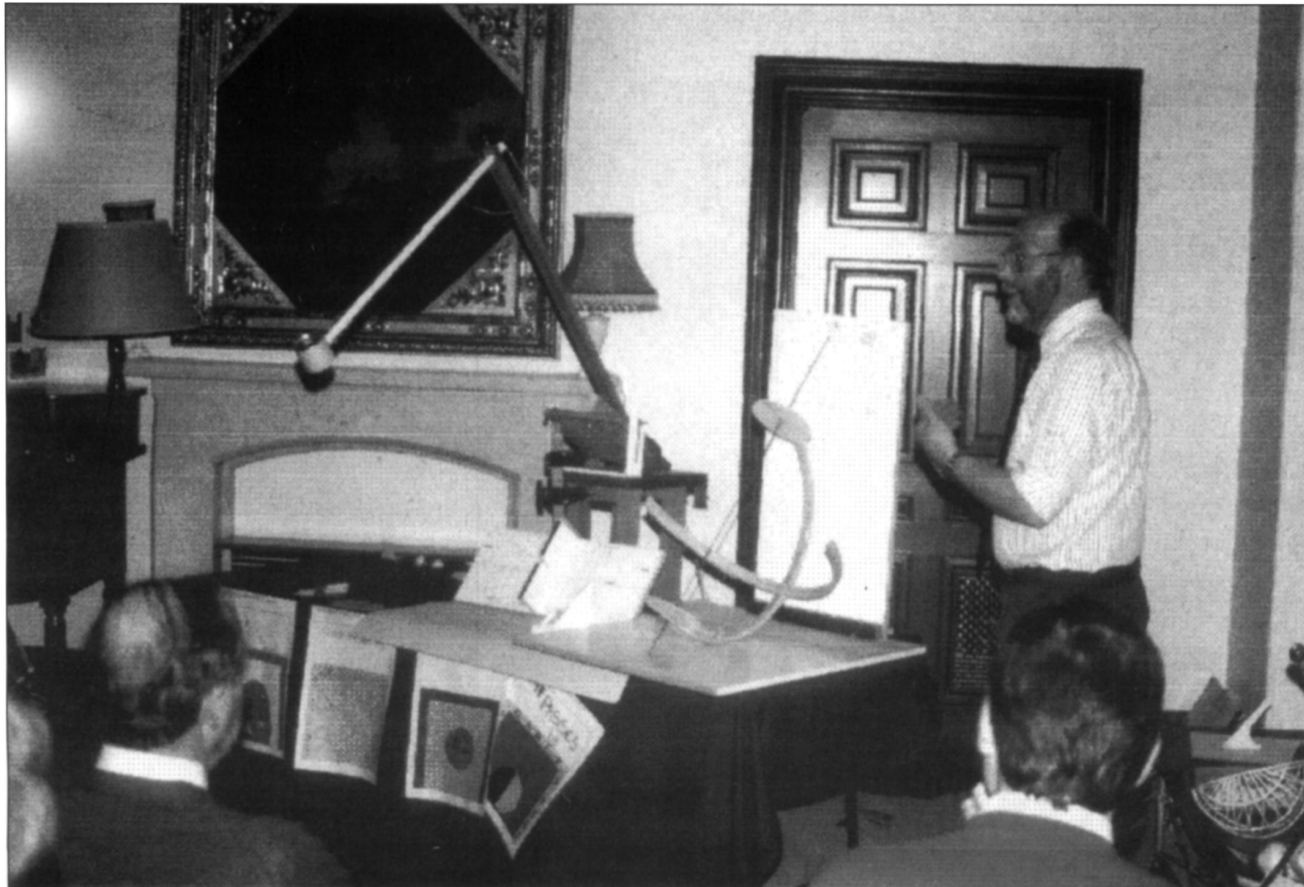

*David Brown at Edinburgh*

The re-election of the Council brings us to a point where we had a firmly based and democratically elected governing body, a steadily growing membership, and a widely respected journal edited by one of the founder members,

Charles Aked. The final instalment of this brief history will cover the period to our tenth anniversary, but in much less detail.

## DIAL DEALINGS 2002

MIKE COWHAM



In the last year there was only one sale that could be described as 'special' but despite that there were a few interesting dials and a few surprises. I will take the sales in date order omitting those that had few sundials of note. All prices quoted are hammer prices to which are normally added 17½% premium and VAT.

### CHRISTIES, 11 APRIL 2002.

I have chosen here two dials that are of some particular interest. The first, a gilt brass diptych dial by Marcus Purman dated 1594, (Fig. 1.), is one of several of this type known. A similar dial by Ulrich Schniep, '15°V\*S\*85', was sold later in the year by Sothebys. These dials are all most attractive and well engraved, and when closed fit tidily into the pocket being only about 5.7cm wide. An attractive bracket with a built-in plummet holds the string gnomon. Although estimated £15,000 - £20,000 the Purman only made £12,000.

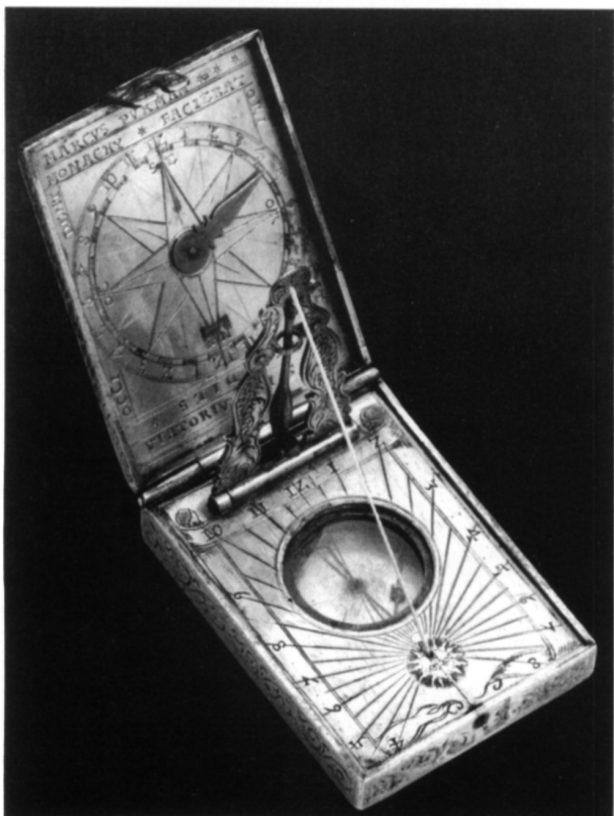

Fig.1. Dial by Marcus Purman of Munich

Also in this sale was an analemmatic dial by Thomas Tuttell, c1697, with the two halves hinged together, (Fig. 2.). This is the type of dial that Tuttell is best known for. It can be used over a fairly wide range of latitudes by tilting the dial plate, the plummet indicating against a scale

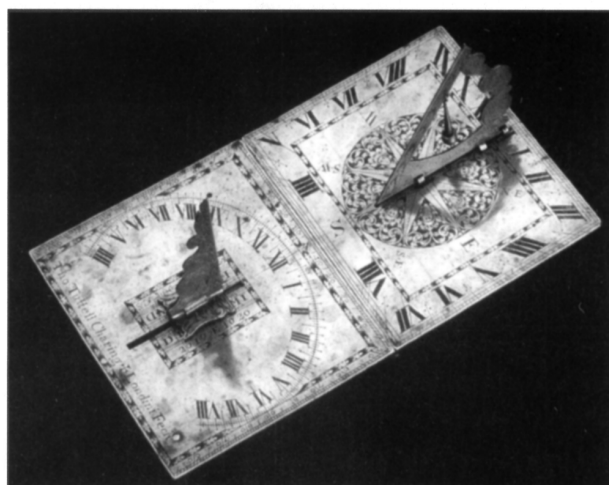

Fig.2. Analemmatic Dial by Thomas Tuttell.

between 30° to 80°. On its underside is a detailed Perpetual Calendar engraved for the years 1697 to 1758. This dial was possibly made for export to France being engraved on the underside '**Fait par Tuttell Ingenieur pour les Instrumens de Mathematique a Charing + a LONDRE**'. One thing against this theory is that it still uses the 'Old Style' Julian Calendar, which was still current in England but certainly not in France. It was sold for £7,000.

### SOTHEBY'S OLYMPIA, 30 MAY 2002.

In this sale was a most exciting Perpetual Calendar, (Fig. 3.). Although not strictly a sundial I can not let it pass without comment. It was an English calendar, made from silver around 1727. It is certainly the most interesting Perpetual Calendar of its type that I have ever seen. Although only 6.2cm diameter it opens to reveal two extra faces making four in total. This superb quality of calendar was obviously going to make some money. Furthermore, it was inscribed '**George ?????? to his Esteemed friend Isaac Newton**', where the surname of George has been obliterated. This attribution to Newton certainly gave it a push and it made a staggering £26,000, well above its top estimate of £12,000. It will be a long time before we see

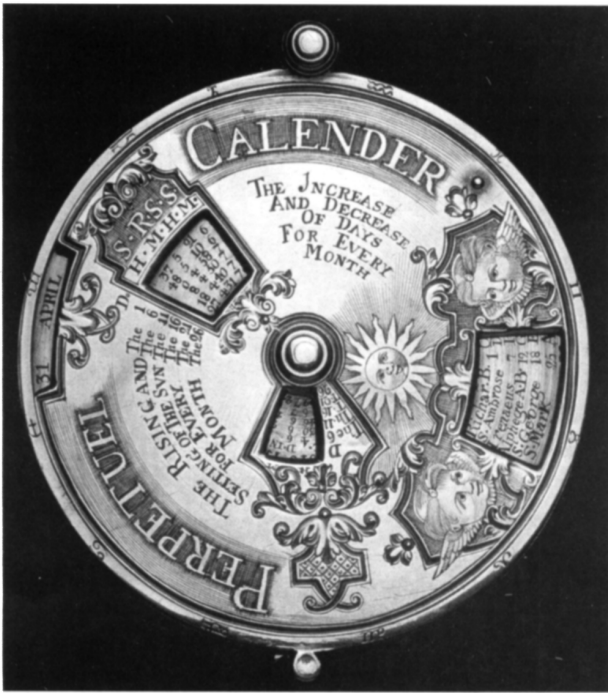

Fig.3. Silver Perpetual Calendar.

another of this quality. I wonder who was the erased 'George' and why someone did this? Could it have been Isaac Newton himself who perhaps fell out with George? We may never know.



Fig.4. Slate Dial by Robert Connell, 1815.

The other item of considerable interest was a fairly large, (20" dia.), nonagonal slate dial beautifully signed 'This was finished with care most fervent by Robert Connell Your humble servant' and 'Made in the year of our LORD. 1815', (Fig. 4.). It is interesting to see that the name Connell has been split between two lines, 'Conn' and 'ell'. He obviously ran out of space even though it was 'finished with care most fervent'! The intended latitude and

longitude, 55° 5' N, 7° 21' W, are engraved on the dial and this places it in Northern Ireland near to Londonderry. It has three different chapter rings to show the time at places such as **Leghorn** (Livorno), **Carthage**, **Philadelphia**, **Jerusalem**, **C. Carmel**, **C. Augustine** etc. Perhaps its owner would have had a son in Philadelphia and he may have traded with someone in Livorno? At the south end of the dial is 'A Perpetual Almanack' giving Leap Years, Golden Numbers and Days of the Week from 1700 to 4099. This is a remarkable slate dial by an, as yet, unrecorded maker, and carrying so much information. It sold for its lower estimate of £1500.

#### SOTHEBY'S OLYMPIA, 30 OCTOBER 2002.

Again there were two items of considerable interest in this sale. The first was a German manuscript book dated 1742 containing a total of 65 pen and ink diagrams of sundials, with local colouring, (Fig. 5.). These diagrams are very competent and it would be interesting to know who the artist was. Although having a top estimate of £400 it eventually sold for £2,200.

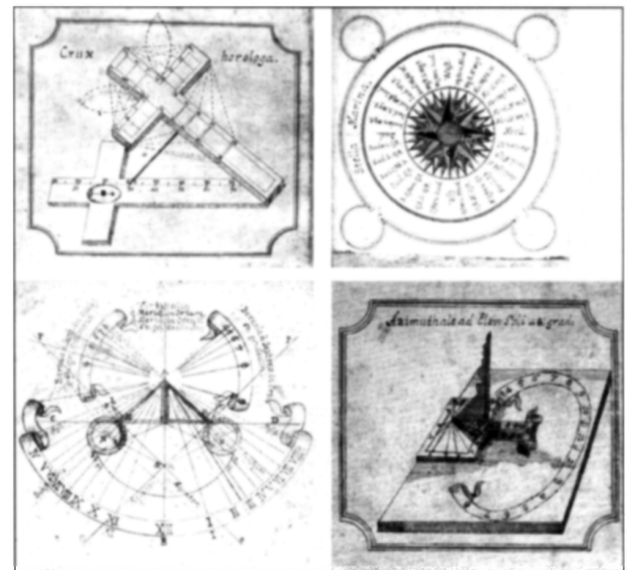

Fig.5. Some Pages from Manuscript.

The other dial is a real rarity – a garden dial signed by **Thomas Tompion**, (Fig. 6.). There are very few of his dials known, and they were usually made to go with his clocks, such as the one at the Pitville Pump Room in Bath. This dial was only 12" square but carries tables for the Equation of Time, split into two halves, each side of the gnomon. Bidding for this was, as expected, very fierce and it eventually made £42,000, a mere six times its top estimate!

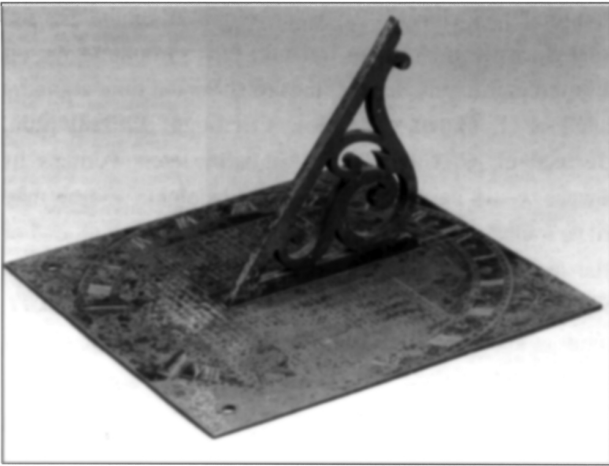

Fig.6. Garden Dial by Thomas Tompion.

**SOTHEBY'S OLYMPIA, 30 OCTOBER 2002.  
MASTERPIECES FROM THE TIME MUSEUM,  
PART THREE.**

This sale was on the afternoon of the previous sale and really did contain some rather special dials with perhaps just a few that were not quite so good. I have chosen just four from the total of 39 lots.

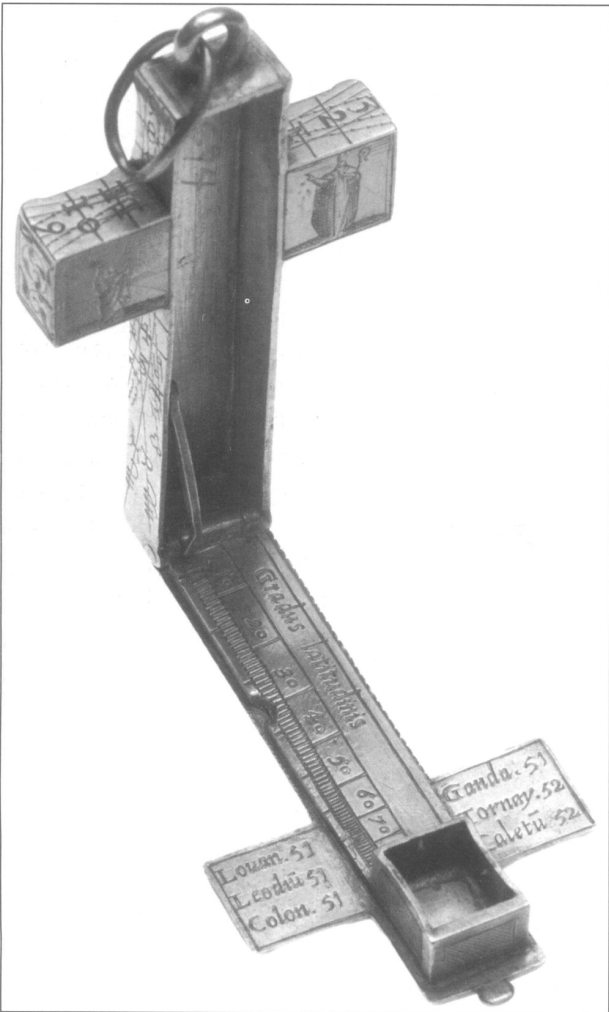

Fig.7. Gilt Cruciform Dial.

A gilt brass crucifix dial attributed to *Adriaan Zeelst* and dated 1589 was on offer, (Fig. 7.). These crucifix dials only rarely appear on the market and this one was a particularly nice example. Such dials would have been worn around the neck, probably of a priest, performing two functions – as a crucifix and as a time teller. This dial sold for £8,500.

An ivory diptych dial in the form of a lute is another rarity, (Fig. 8.). At least two others of this type are known and this is the first to be offered in a sale for many years. The dial is attributed to Hans Troschel the younger of Nuremberg and was probably made between 1614 and 1634. When the dial is closed it is still possible to use the compass through a hole

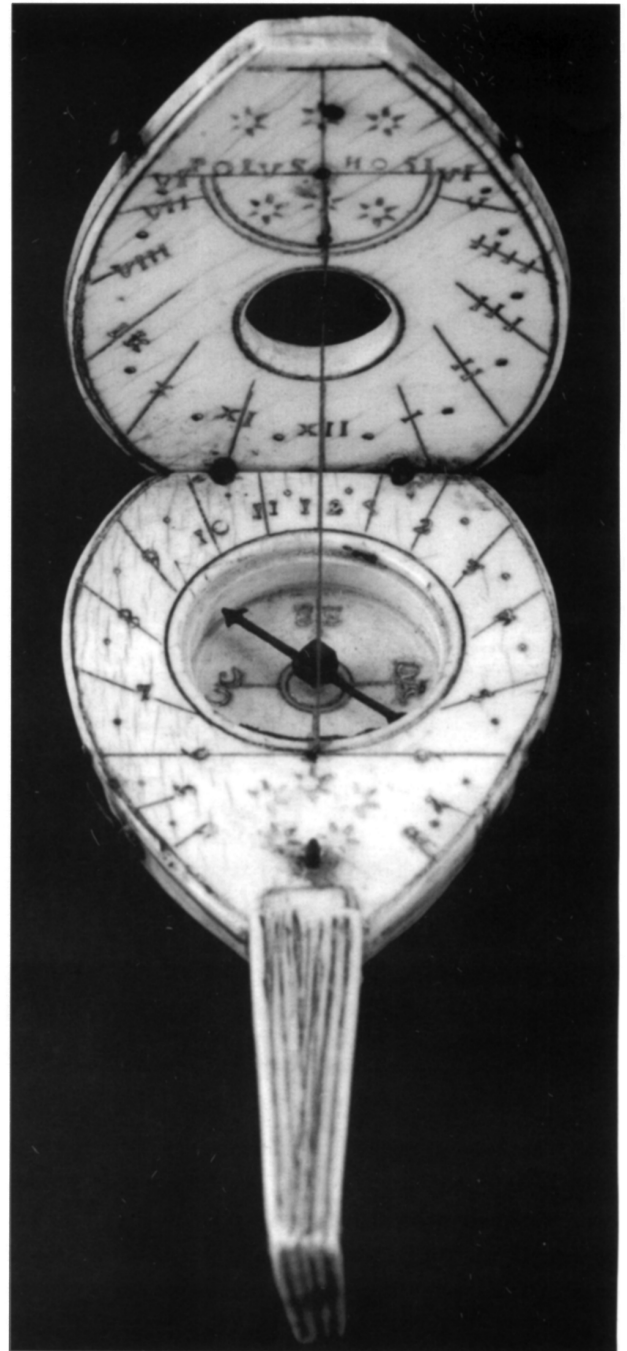

Fig.8. Ivory 'Lute' Dial.

in its upper leaf. This dial would, like the crucifix dial above, be worn on a cord around the neck. It sold for £4,600.

Another type of dial that seldom comes to auction was a crescent dial made by 'Johann Martin In Augspurg 48', (Fig. 9.). These dials are seen in several museums and are always keenly sought after by collectors due to their attractive design. The two crescents are essentially two halves of an equinoctial ring dial and hence need no compass for setting. This dial made £9,000, commensurate with its top estimate.

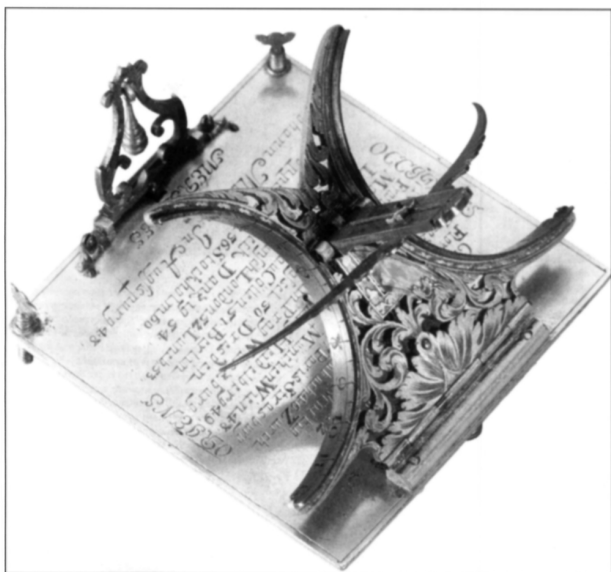

Fig.9. Crescent Dial by Johann Martin.

My final choice from this sale is another rarity, this time a universal equinoctial mechanical dial, sometimes known as a minute dial, (Fig. 10.). Mechanical dials are most often found by continental makers and a few more from Dublin,

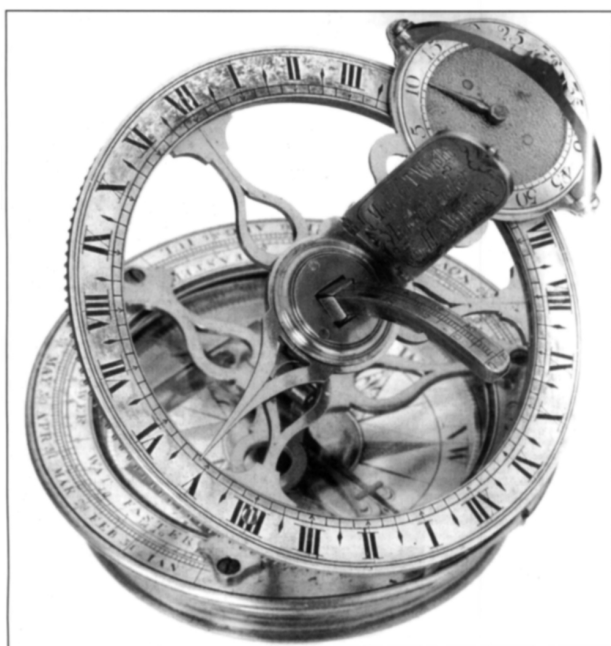

Fig.10. Equinoctial Mechanical Dial by T. Wright.

but this one is English 'Made by T Wright. Infrum. maker to His MAJESTY.' I know of only two similar dials by Wright. In use, the dial is set to face north-south by its compass and is levelled by its built-in spirit levels. The gnomon is the small pinhole in the arc above the minute dial and the sun's rays pass through this onto a line on the reverse of the erect plate. The minute dial is then rotated until this spot of light falls exactly on the inscribed line. The time is then read from the combination of the two pointers, hours on the large scale and minutes on the smaller. Notice too that the Equation of Time is engraved around the edge of the compass. This dial sold for a healthy £9,000.

#### WARNING.

I thought of heading this section 'Dial Misdealings' but thought better of it because the dials that I am about to describe were *perhaps* not intended to deceive. However, there are some replica dials flooding onto the market at present, together with some other types of instrument, such as sextants. These are replicas of actual instruments<sup>2</sup>, probably from India, and normally sell for just a few pounds. The problem is that some people see one of these and think that it is the genuine article, sometimes paying a high price for it. The dials are normally 'inscribed' WEST, LONDON, - (actually the inscription is part of the casting). They are at first sight attractive and their boxes are plainly new. Their brasswork is also usually highly polished. The real thing would be fairly dull and all of its edges would be crisp, not rounded by polishing. Furthermore the chapter ring would have been silvered. I have seen two models of this dial, one a simple London-type inclining dial and the other a larger and more complex version of the same with three levelling screws. As far as I know they work correctly but they should *never* be mistaken for the real thing which would normally sell for several thousand pounds. I have seen these in several antique shops and even a market stall in Oxford but I have been distressed to hear from two BSS Members, who having purchased them have asked my opinion. I hate to be the carrier of such bad tidings. You have been warned!

#### PROJECTED SALES FOR 2003.

##### Bonhams.

Details of sales for this year not finalised.

Contact:- James Stratton. 020 7468 8364.

##### Christie's South Kensington.

10 April - Exceptional Scientific and Engineering Works of Art

1 July - Scientific, Medical and Engineering Works of Art

4 November - Scientific, Medical and Engineering Works of Art

Contact:- Tom Newth. 020 7321 3147.

### Sotheby's.

20th March - The James Watt Sale, with Scientific Instruments & Books - Bond Street

7th May - Scientific Instruments - Olympia

28th October - Scientific Instruments - Olympia

Contact:- Catherine Southon. 0207293 5209.

### Fairs.

34th Scientific & Medical Instrument Fair. 27 April 2003.

35th Scientific & Medical Instrument Fair. 26 October 2003.

Both are Held at the Radisson SAS Portman Hotel, Portman Square, London, 10:00 to 16:00.

Contact:- Talbot Promotions. 020 8969 7011.

### ACKNOWLEDGEMENTS.

I would like to thank the following for allowing me to use their photographs.

Christie's South Kensington for Fig. 1 & Fig. 2.

Sotheby's Olympia for Fig. 3, Fig. 5, Fig. 6, Fig. 7, Fig. 8, Fig. 9 & Fig. 10.

These pictures remain their copyright.

---

## NOTES FROM THE EDITOR

### SPACE FILLERS

Readers may have noticed that odd corners of the Bulletin—a quarter-column here, and half-column there—are filled by random photos or sketches of sundials. (Our printer does not like seeing a white blank space). Since these pictures have no captions, they sometimes arouse curiosity, and this note will satisfy queries arising from last December's space-filler pictures.

Cross Dial, p.154: in a private cottage garden in Cumbria (Photo: M.Kenn)

Multiface Dial, p.157: at Wilhelmsbad, Germany (Photo: S.Adam)

Armillary Sphere, p.162: at Frankfurt, Germany (Photo: S.Adam)

Dial and EoT Graph, p.166: at Homberg, Germany (Photo: S.Adam)

The sketches on pp 166 and 167 are taken from "Ye Sundial Booke" by Geoffrey Henslow published in 1914, a collection of sketches and poems about sundials. The sketch on p.167 shows the dial at the Santa Barbara Mission in California. The site of the sundial picture on p.166 is not identified.

The next group of space fillers will be derived from a collection of Wills Cigarette card pictures; we are grateful to Mike Cowham for supplying these. For this series, curiosity will be instantly satisfied, since the place-caption is part of the picture.

### GIFT

We have received a gift, a newly-published book on 'Sundials', from its author, Dr. Milutin Tadić a member of the BSS living in Kraljevo, Bosnia. The letter of thanks sent to Dr. Tadić has been returned, marked 'Insufficient address'. The letter was sent to the same address as that used for the circulation of the Bulletin of the BSS. We hope that this note, in the March 2003 Bulletin, will reach the

donor and will be accepted as conveying our gratitude for his gift, and our congratulations on the publication of this well-produced and well illustrated volume.

### A CORRECTION

Yes, another error, in the Bulletin Vol. 14iv (December issue). In the report of the Newbury Meeting, the photograph on page 159 (2nd column, top photo) should have been captioned "Mike Shaw demonstrates his remote-sensing fibre-optics dial". Many apologies to all, including Mike Shaw, Silas Higgon, and especially Peter Ransom, who took the photo.

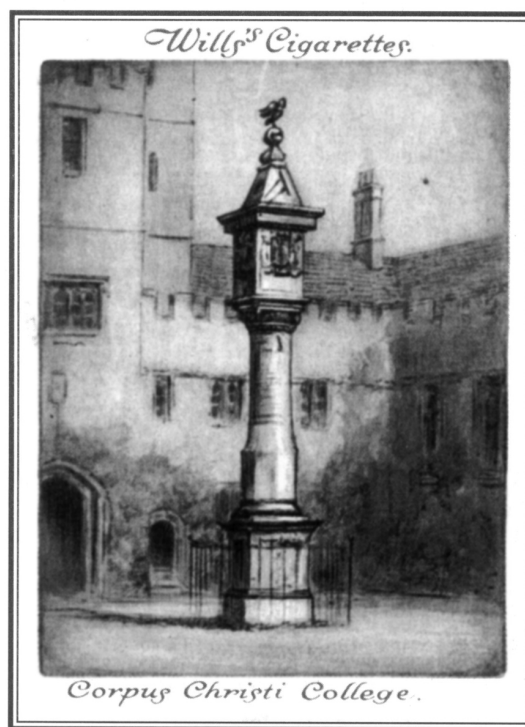

# TWO FURTHER CHINA DIALS

A.O. WOOD

Peter Ransom's article on these miniature dials (ref. 1) made me keep my eyes open in antique or junk shops and patience was rewarded recently with the two dials in the photograph.

Both are by Carlton, one of the well known makers following Goss whose name attaches to these sorts of things.

The smaller square section one has the Birmingham coat of arms, not a very seaside town one might think; but the taller baluster pedestal dial is firmly at the seaside in Herne Bay, Kent. Herne Bay's 'Coat of Arms' is in fact a shield with three local 'connections' depicted, I suspect because Herne Bay did not have its own arms, being part of the Canterbury conurbation.



*Fig.1a.*

The three items are: (a) Reculver Towers, the remains of Reculver Church preserved because the twin towers were an important landmark and aid to navigation in the Thames estuary,

- (b) a heron, the 'herne' of Herne Bay and
- (c) the free standing public clock along the sea front, apparently one of the oldest.



*Fig.2.*

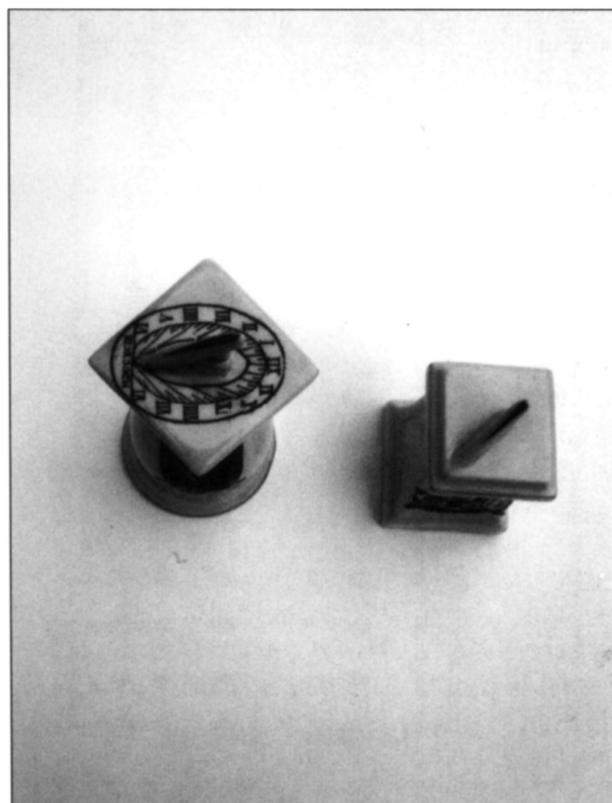

*Fig.3.*

Additionally, this larger dial has its face delineated, very neatly, with noon to north, but a vertical dial face has been used. There is the date 1793 along the top in Roman numerals.

These dials have now joined the other four in Peter's collection.

**REFERENCE**

1. P. Ransom, 'China Sundials', B.S.S. Bulletin Vol 11 (ii) June 1999 p76.

*Authors address:  
5 Leacey Court  
Churchdown, Gloucester*

## A MERIDIAN LINE IN PALERMO CATHEDRAL

**MARGARET STANIER**

By the kindness of a friend who was on holiday in Sicily in summer 2002, I have received information about a meridian line laid out on the floor of the cathedral in Palermo: one more line to be added to the list of 12 ecclesiastical meridian lines given to us by the late Charles Aked in his Andrew Somerville Lecture of 1997. My friend was able to take some photographs and to bring back a copy of the Cathedral guide-book, from which most of the information below has been taken.

The cathedral, originally a Gothic-Norman structure, was heavily restored and transformed in the period 1781 to

1801, and is now in neo-classical style. The meridian line, dated to 1801 and designed by the Theatine astrologer Piazzi, belongs to this restoration period. It is made of a brass shaft embedded in a marble strip. Polychrome inlays at intervals show the signs of the zodiac. The line crosses the floor near the eastern end of the nave, from a point close to the side chapel of St. Francis di Paola in the south aisle, to a point on the north side of the nave, under the dome. At mid-day a ray of sunlight passes through a hole in the dome near the St. Francis chapel and illuminates 'the current sign

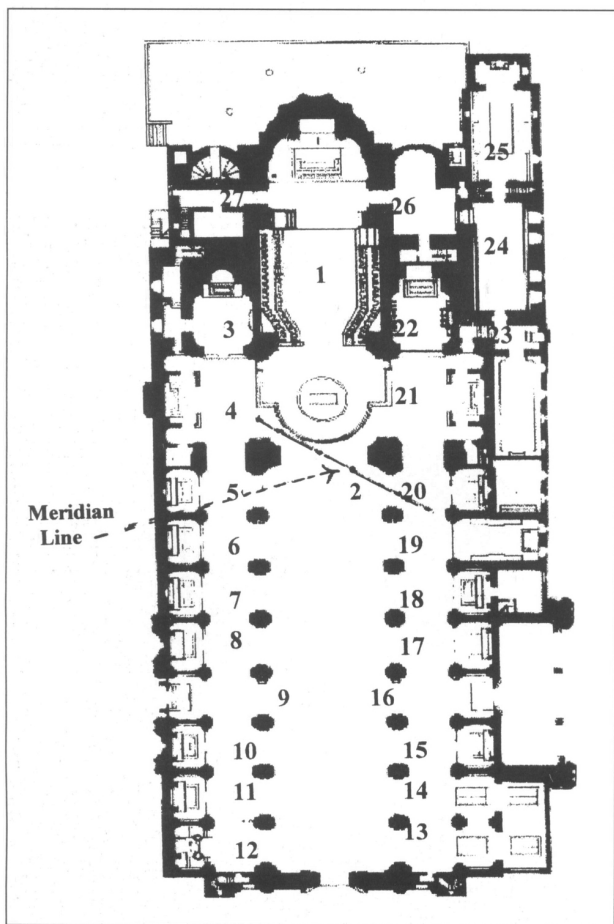

*Fig.1. Plan of cathedral floor showing position of meridian line*

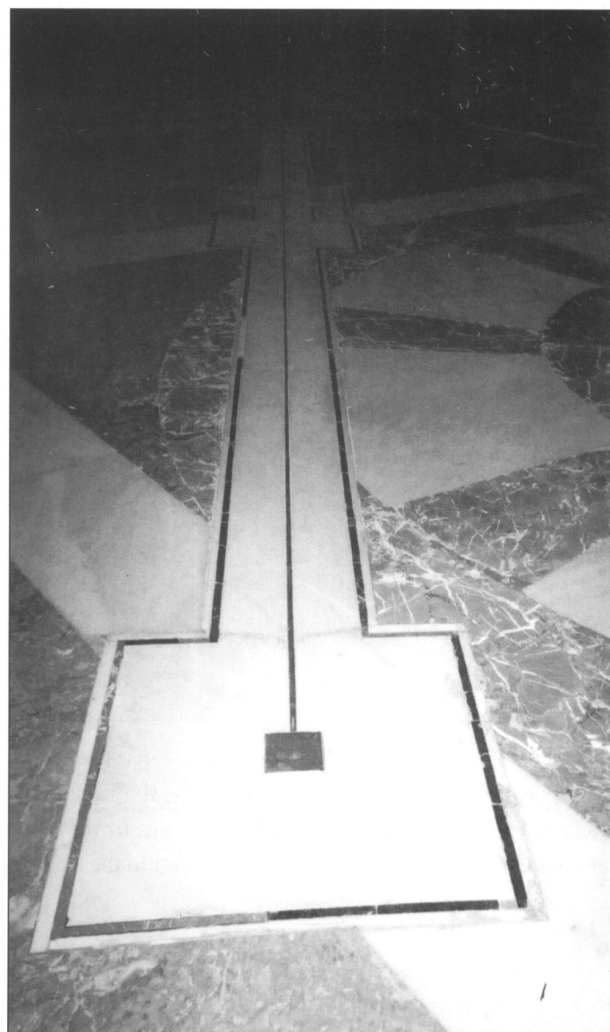

*Fig.2. 'Winter Solstice' end of line*





*Fig.3. Summer end of line with zodiac symbols*

of the zodiac'. This cathedral has no transepts, and the line running diagonally across the nave shows that the main axis of the Cathedral was not built on a direct east-west line. (See Fig.1). At one end of the line there is a plaque giving information about it, and a bronze rod giving a 'span', a measurement valid at that time in the Kingdom of Sicily,(Fig.2) . Fig. 3 shows the summertime end of the line, with the symbols for Gemini, Cancer and Leo. Other zodiac symbols are shown in Fig 4 (Virgo and Taurus) and Fig. 5 (Scorpio and Pisces).

According to Charles Aked's account, another meridian line on the island of Sicily, in the cathedral at Messina, was built a few years later than the one at Palermo, but destroyed by an earthquake early in the 20th century and never replaced. It is gratifying that the island still possesses a handsome meridian.



*Fig.4. Virgo and Taurus*

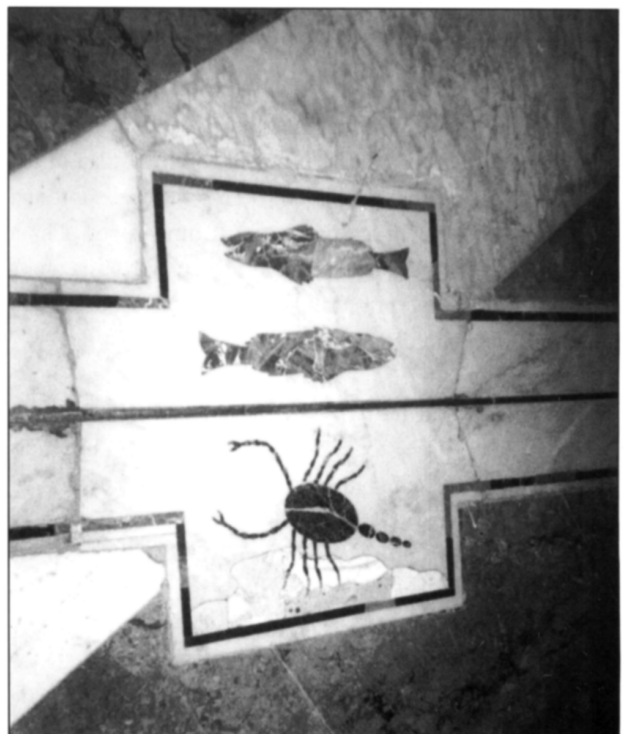

*Fig.5. Scorpio and Pisces*

# THE WHIMSICAL ORIGIN OF DAYLIGHT SAVING

CHRIS PARSONS

*[The letter below, sent to us by our member D.K. Ebdon, first appeared in November 2002 in 'The Herald' of Glasgow. It is reprinted by permission of the writer and of the editor of The Herald]*

The adjustment of the clock to suit our lifestyles can be more than a compromise. If we regard local noon as the time when the sun is due south, noon would move westward at the latitude of Glasgow at about 10 miles a minute so Glasgow would be about four minutes later than Edinburgh in local time. That was fine when the horse was our fastest transport, but steam trains meant that travellers had to change their watches very frequently. Time zones, areas where all the clocks were synchronised, solved that, zones being approximately one hour or fifteen degrees of longitude. The approximation took care of states which spilled over into the next zone.

The effect of zones was that in middle latitudes it was not too difficult to get people to adjust their lives to blocks of solar transit. However, as correspondents say, there is a north-south aspect too. When you live in extreme latitudes where days and nights, judged by sunshine, can each last for months, the clock serves a different function. The major difficulty comes in the intermediate latitudes where you get very long summer, and very short winter, days, especially the latter.

Time zones are not absolutely necessary for the conduct of everyday life. You can adjust your life style instead of the clock and that is what people did before fast transport and ubiquitous clocks. On a world map of time zones, China span 79° E to 134° E but is a single time zone. Russia on its northern border is split into four one-hour zones Each country has its choice.

The trouble is that the UK seems too small to split into different solar time zones and even countries such as Norway that have cities in high latitudes don't have N—S time zones.

Time zones can give odd effects. If it is shortly after midnight in the UK and an e-mail is sent across the Atlantic requesting a quick answer, the date of the received answer can be the day before the original letter. We regard the attack on Pearl Harbor as taking place on December 7 but to the Japanese it was December 8.

There were economic benefits in daylight saving. In the war the UK and Northern America worked permanent summer time and double summer time. Fuel was saved because many activities can be scheduled to need minimum artificial light. Daylight saving makes no difference to factories working around the clock, or to farm animals. The argument is that the advantages to many outweigh the disadvantages to the few.

The idea of daylight saving came from Benjamin Franklin as a whim in a humorous essay in 1784. People then worked mainly in villages and had no need or means of synchronising with others even a few miles away. Franklin knew there was no such thing as a free lunch, so I suppose he never expected his daft idea to be adopted.

*Authors address:  
Chris Parsons,  
40 Bellshill Road,  
Uddingston,  
Scotland*



# TO ESTIMATE THE DECLINATION OF A DIAL

JOHN FOAD

## THE SUBSTYLE TIME

In an article in the Bulletin of June 1999, David Young gave a convenient way of estimating the declination of a vertical dial. His method used the fact that the gnomon of a declining dial is offset from the vertical noon line. The time corresponding to the position of the substyle can be tabulated to indicate the declination for which the dial was designed. The relationship is:

$$\tan(\text{Declination}) = \tan(\text{hour angle}) \times \sin(\text{latitude})$$

For example if the substyle lies on the ten am hour line, the hour angle is  $-30^\circ$ . At a latitude of  $51.5^\circ$ , we have

$$\tan(\text{Declination}) = \tan(-30) \times \sin(51.5) = -0.5774 \times 0.7826 = -0.4519$$

and hence Declination =  $-24^\circ$ , or  $24^\circ$  East.

The substyle time for a range of declinations is shown in Table 1, which is similar to Mr Young's table. The calculations are for the latitude of London. As an illustration of the difference to be expected at other latitudes, Table 2 shows the results for Edinburgh.

Declination, degrees	South Dial Declining East		South Dial Declining West	
	Substyle at Time	Time on Horizontal	Substyle at Time	Time on Horizontal
0	12:00	6:00	12:00	6:00
2.5	11:47	5:52	12:13	6:08
5	11:34	5:44	12:26	6:16
7.5	11:22	5:36	12:38	6:24
10	11:09	5:29	12:51	6:31
15	10:44	5:13	1:16	6:47
20	10:20	4:56	1:40	7:04
25	9:57	4:40	2:03	7:20
30	9:34	4:23	2:26	7:37
40	8:52	3:47	3:08	8:13
50	8:13	3:08	3:47	8:52
60	7:37	2:26	4:23	9:34
70	7:04	1:40	4:56	10:20
80	6:31	1:00	5:29	11:09

Table 1. Substyle Position, and 'Horizontal' Hour, for Different Declinations, Calculated for a Latitude of  $51\frac{1}{2}^\circ$  (London)

Sometimes however the gnomon is simply an inclined rod or bar with no clear substyle position, and here we need another method. This note suggests two more possibilities.

## THE HORIZONTAL TIMES

In a Direct South dial, six am and six pm lie on the horizontal line through the root of the gnomon. If the dial

Declination, degrees	South Dial Declining East		South Dial Declining West	
	Substyle at Time	Time on Horizontal	Substyle at Time	Time on Horizontal
0	12:00	6:00	12:00	6:00
2.5	11:48	5:52	12:12	6:08
5	11:36	5:43	12:24	6:17
7.5	11:24	5:35	12:36	6:25
10	11:12	5:27	12:48	6:33
15	10:48	5:10	1:12	6:50
20	10:25	4:53	1:35	7:07
25	10:03	4:35	1:57	7:25
30	9:41	4:18	2:19	7:42
40	8:59	3:41	3:01	8:19
50	8:19	3:01	3:41	8:59
60	7:42	2:19	4:18	9:41
70	7:07	1:35	4:53	10:25
80	6:33	12:48	5:27	11:12

Table 2. Substyle Position, and 'Horizontal' Hour, for Different Declinations, Calculated for a Latitude of  $56^\circ$  (Edinburgh)

declines to the East, the horizontal will show an earlier time, and similarly will show a later time for West decliners. This gives a second estimator, which can be tabulated along with the "substyle time", and is also given in Tables 1 and 2.

The relationship is :

$$\tan(\text{Declination}) = -\cot(\text{hour angle}) / \sin(\text{latitude})$$

## THE CORNER TIMES

Fig 1 shows a dial at Christ Church, Oxford (SRNO 0607) where neither of the above methods can be used. The substyle is not present, and the root of the gnomon lies outside the frame of the dial, so the "horizontal times" are not available. However it happens to be a rectangular dial, with the noon line central, as can be seen even though the photograph was taken obliquely, by drawing in the

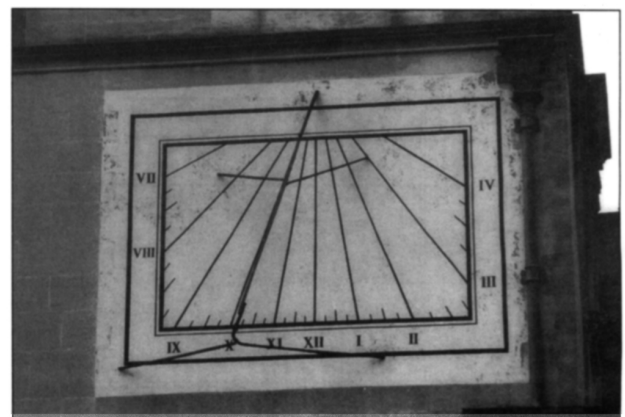

Fig.1. Christ Church, Oxford (SRNO 0607)

diagonals. In such a case, which is not uncommon, we can use the times at the two lower corners to estimate the declination. The relationship here is:

$$\text{Tan (Declination)} = - (\text{Cot } h1 + \text{Cot } h2) / (2 \times \text{Sin (latitude)})$$

where h1 and h2 are the hour angles of the two "corner times".

Taking the Christ Church dial as a practical example, the corners are at about 8:51 am and 2:42 pm, giving h1 = -47.25° and h2 = +40.5°. The latitude is 51.7° for Oxford, and we get

$$\text{Tan (Declination)} = - (-0.9244 + 1.1708) / (2 \times 0.7848) = - 0.157$$

giving a Declination of 9° East.

In fact it is not necessary for the dial to be rectangular. All we need to do is to identify two times (morning and afternoon) which are at the same height on each side of the dial, and equidistant from the vertical XII line. If the dial is hexagonal or octagonal, two opposing corners can be taken, and we then work as above. Even if it is circular or oval, we can proceed by using any two times which are at exactly the same height on the dial, which we can find from a good photograph taken from directly in front. Any dial whose frame is symmetrical about the noon line can be treated in this way.

Finally, the noon line may not always be central. In this case, referring to Fig 2, call the distance to the left of the noon line one unit, and the distance to the right K units.

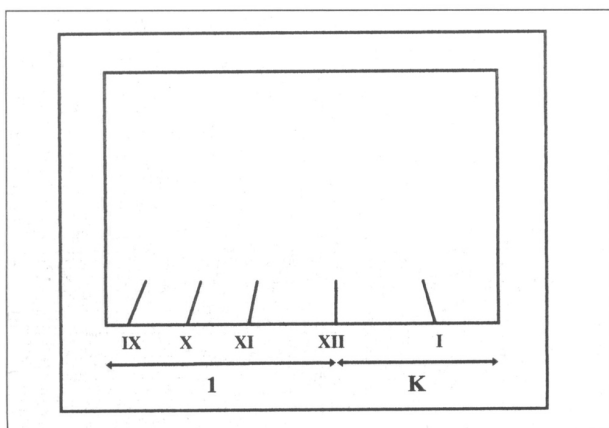

Fig.2. Illustrating the calculation of "K" for a non-central Noon Line

The relationship then becomes :

$$\text{Tan (Declination)} = - (\text{Cot } h1 + K \times \text{Cot } h2) / ((1 + K) \times \text{Sin (latitude)})$$

An extreme example of the method can be found with the Wren dial on the wall of the Codrington Library at All Souls, Oxford (SRNO 0987), Fig 3. At first glance this appears intractable, with no substyle, horizontal times not clear, no "corners", and XII not central. A faint stonework line allows a horizontal to be identified, even when photographed obliquely. The times at this horizontal are about 7:40 am and 8:46 pm. Measuring across to the noon line gives a value of K at this position of 0.66. Working through the formula with an Oxford latitude of 51.7°, we get to a designed declination of 12° E, which agrees well enough with the figure of 13° E stated in the Register.



Fig.3. All Souls, Oxford (SRNO 0987)

#### ACCURACY

These methods are not for those who need answers to within a few minutes of arc. The accuracy depends on how well we can read the time at the substyle, the horizontal, or the corners, and this is not as easy as I had at first expected. However, having now used and cross checked the methods extensively, I find I can usually get to within 2 or 3 degrees of the true figure. Careful reading of the times will repay the trouble taken.

#### CONCLUSION

For the Substyle Time and the Horizontal Times, the table in Table 1 gives the simplest way of finding the declination for which the dial was designed.

The formulae for the "Corner Times" method may look a bit forbidding, but are simple enough to work through with Trig Tables and a calculator. It is very satisfying with their help, or with the table, to discover the declination of a dial that is otherwise inaccessible.

John Foad  
Greenfields, Crumps Lane  
Ulcombe, Kent ME17 1EX

# THE SUNDIALS AT THE SKALNATE PLESO OBSERVATORY, IN POPRAD (SLOVAK REPUBLIC), AND IN OTZENHAUSEN (GERMANY)

E.Th. THEODOSSIOU, P.G. MARCHOS & V.N. MANIMANIS

## ABSTRACT

Three vertical sundials of distinct appearance in Central Europe, all at latitudes between  $49^{\circ}$  and  $50^{\circ}$  N, are presented. The first is on the wall of the Observatory building of Skalnaté Pleso, at an altitude of 1778 m on the High Tatras Mountains of the Slovak Republic. The second is on a church in the city of Poprad, also in the northern Slovak Republic. The third vertical sundial is in the area of Otzenhausen, Germany.

Key words: Central Europe, observatories, churches, Slovak Republic, Germany

## 1. THE SUNDIAL AT THE SKALNATÉ PLESO OBSERVATORY

The Slovak Republic is a country at the heart of continental Europe without access to the sea. It borders with Austria to the W-SW, with the Czech Republic to the NW, with Poland to the North, with Ukraine to the East and with Hungary to the South. We were acquainted with the Slovak Republic after a series of frequent visits to that country during the last five years due to a bilateral scientific project of Greece and the Slovak Republic ('Long-term Photometric Monitoring of selected symbiotic and cataclysmic variable stars'). We were able to travel extensively through the country, visiting its institutes of Astrophysics and its observatories. The country is full of small observatories and planetariums, while in many cities and towns we found public buildings, churches and observatories to be decorated with sundials.

The High Tatras (Vysoké Tatry) Mountains have many tall peaks, the highest being Gerlachovský štít (2655 m) near the borders with Poland; we saw it while climbing on a cable railway to the Lomnický štít Observatory (on Lomnický štít, 2632 m) for observations. We started from Lanová Draha (Kabin Ková) at 903 m and reached the starting point of the cable railway (Start, altitude 1173 m). The first stop is at Skalnaté Pleso (1751 m) and the second and last at Lomnický štít. The Tatras, both High and Low (Vysoké and Nizke Tatry), like the Alps, have the form of a geologically young mountain range, with acute peaks and steep, craggy slopes. They bear the marks of glaciers of the Ice Age, which on the High Tatras have created the high-altitude lakes, very small and peculiar but picturesque, the so-called *eyes of the sea*. One of these, being nearby, gave

its name to the Skalnaté Pleso Observatory, which means 'Observatory of the Frozen Lake' at an altitude of 1778 m. An observatory (Fig.1) was erected in 1942 by the astronomer Antonín Bečvář, famous for his sky maps (Atlas Coeli, Eclipticalis, Borealis).



Fig. 1: E. Theodossiou and P. Niarchos in front of the Skalnaté Pleso Observatory, erected during World War II, at an altitude of 1778 m above sea level.

The facade of this observatory, whose geographic coordinates are  $49^{\circ} 11' N$  and  $20^{\circ} 14' E$ , is decorated with a vertical sundial, drawn on its southern wall. This sundial has a metallic gnomon whose base sits inside an Egyptian Ankh, the cross of life of the Egyptians, or of Akhenaton or



Fig.2: The vertical sundial of the Skalnaté Pleso Observatory. The golden garland bears the inscription *Horam Umbra Monstrat* with light blue capital letters (difficult to see).

Ammon. This cross in turn is inscribed in a yellow sun, and under it there is a golden garland bearing the Latin inscription *HORAM UMBRA MONSTRAT* (the shadow shows the hour). The outer part of the gnomon ends at a circular disc in order to enhance the sharpness of the shadow, an unusual feature for sundials. On the brick wall of the observatory are drawn the hour lines (Fig. 2).

## 2. THE SUNDIAL IN POPRAD

When we arrived in the Slovak Republic, our Slovak colleagues awaited us in the capital, Bratislava. From there we went to Hlohovec, near Trnava, where we spent the night at the local observatory. Then, in order to be close to the Astronomical Institute of the Slovak Academy of Sciences, we settled in the small town of Veľka Lomnica, less than 20 km downhill (SE) from Skalnaté Pleso (Fig. 3). The main city of this area is Poprad (49° 03' N, 20° 18' E),



Fig.3: Large-scale topographic map of the region to the north of Poprad showing also Skalnaté Pleso.

named after the river which crosses it and then flows to the North, enters Poland and finally its waters join the waters of Wisla (Vistula). Poprad is a friendly city with a good city plan, beautiful squares and several churches, such as St. Egidius, Santa Maria and St. Nicholas (Sv. Mikuláša). In Poprad and in Trnava we found churches and private houses decorated with sundials. A peculiar vertical sundial on the wall of the church of St. Nicholas in Poprad (Fig. 4) is associated with a square relief image of St. George



Fig.4: A view of St. Nicholas' church, in Poprad, with the statue of the Slovak poet Janko Krall (1822-1876).

killing the dragon. Its triangular gnomon straddles the image with its three rods. The three shadows meet the eight hour-marks designated with metallic bolts on the church wall. There are no hour lines (Fig. 5).

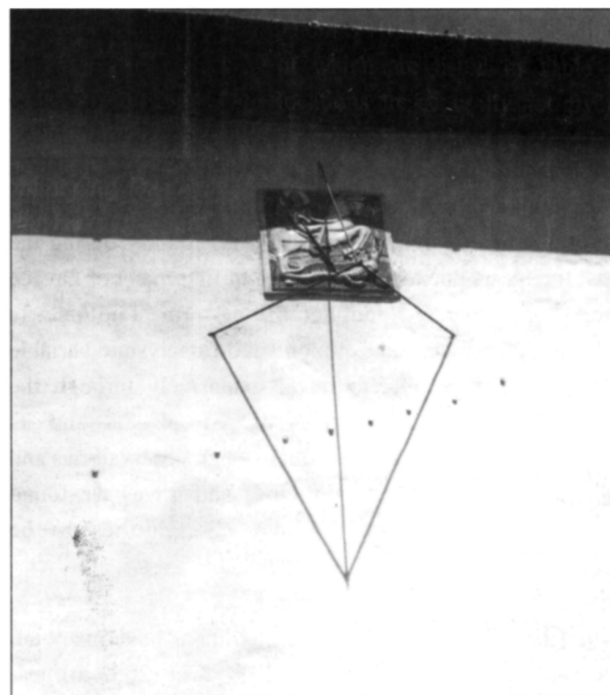

Fig.5: The vertical sundial decorating the wall of St. Nicholas' church, in Poprad.

We also visited Zvolen, with its beautiful castle, and Banská Bystrica, a characteristic Slovak city at the centre of the country, which competed with Bratislava for the title of the country's capital after the secession from the Czech Republic. We stayed there for two days and we were impressed by the huge main square, where various cultural events were taking place. Even more beautiful was its market at night, illuminated from its many lights. Banská Bystrica was the scene of an organised revolt against the German occupation forces in August 1944; however, the

German forces surrounded the city and within two months (October 27) suppressed every organised revolt in the country. A few groups of partisans continued to fight in the mountains. A city is still named after them (Partizánske); we visited its observatory, Hvezdáren Partizánske.

### 3. THE VERTICAL SUNDIAL IN OTZENHAUSEN

Our travel ended with a visit to the German town of Otzenhausen. This town is known because of its Celtic Ring Wall. The historical monument - the *Murus gallicus* as Julius Caesar called it - is the largest and the best preserved fortification of the Celts. The big city of the region is Trier (49° 45' N, 6° 38' E).

In Otzenhausen, at the Youth Hostel, we photographed an exquisite vertical sundial. The metallic gnomon of this sundial is fixed at the centre of a sun with flame-rays. The hour lines are short arrows corresponding to the hours from 7 a.m. to 6 p.m., the hours being denoted with Arabic numerals. On top of each one of these numbers there is a smaller Arabic numeral, which shows the corresponding Daylight Savings Time, i.e. + 1 hour. So their range is from 8 a.m. to 7 p.m.

Under the sun which supports the gnomon there are two arcs. The upper signifies the winter solstice with the respective zodiacal symbol of Capricorn, while the lower

arc signifies the summer solstice with the respective zodiacal symbol of Cancer. Between them there is a straight line corresponding to the equinoxes: on its right-hand edge there is the symbol of Aries, indicating the vernal (spring) equinox, while on its left-hand edge there is the symbol of Libra, indicating the autumnal (fall) equinox (Fig. 6).

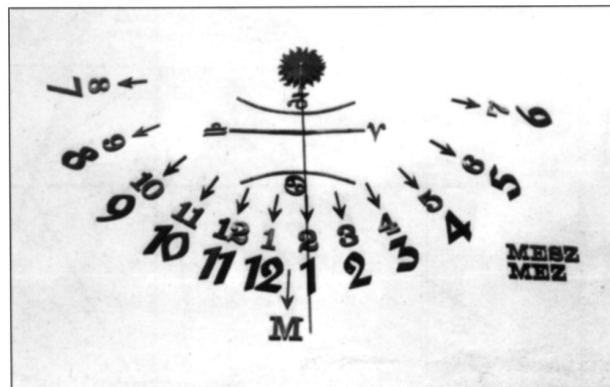

Fig.6: The vertical sundial on the wall of the Youth Hostel of Otzenhausen, Germany.

Address of the authors:  
 Department of Astrophysics, Astronomy and Mechanics,  
 School of Physics, University of Athens,  
 Panepistimiopolis, Zographou, GR 15784 Email:  
 etheodos@cc.uoa.gr

## FROM WILLIAM LEYBOURN, 1700

[The item below was among the material which we received in 1997 from Mr. C.K.Aked, the first Editor of the Bulletin of the BSS. It may provide an interesting challenge for those who enjoy the manipulation of ruler, compass, square and plumb-line. If you get stuck, consult Fred Sawyer in Bull.BSS. 94.1 p22.---Ed.]

**CHAPTER XI from William Leybourn: DIALLING...**  
**Second edition, 1700, pp95-98** *The text modernised by Charles K. Aked*

**TO DRAW A DIAL ON FLAT SURFACES BY MEANS OF THREE SHADOWS OF A STYLE CAUSED BY THE SUN ON THE SAME SURFACES IN ONE DAY,**

**WITHOUT KNOWING THE SUN'S DECLINATION, THE ELEVATION OF THE POLE OR SITUATION OF THE PLANE.**

In Fig 1 let the plane be CDF, and the style AB, whether perpendicular to the plane or not, for it is sufficient to know the shadow of the extremity B, viz DEF, observed on any

one day by means of three shadows, and of the style AB, to trace a dial suitable for the place of observation.

From point B (the extremity or top of the style), with the aid of a square draw EC perpendicular to the plane to meet it at point C (if the style is not perpendicular, then from C to the points DEF, draw lines CD, CE, CF.

Then (Fig 2) draw a straight line at will 1.4 equal to CF, and take therein a line 1.2 equal to CE, and 1.3 equal to 2CD, draw the vertical lines 2.5; 3.6; 4.7 from the line 1, 4, each equal to BC - the height of the style in Fig 1; then from point 1 to each of the points .5, 6, and 7 let straight lines be drawn as 1.5 : 1.6 : 1.7 : making with 1.4 the angles 5.1,2 ; 6.1, 3 ; 7.1,4 ; in degrees to the height or elevation of the sun above the horizon at the time of the observation of the shadows, viz the angle .5.1.2, the shadow being at E; 6.1 .3 the shadow being at D; and 7.1.4 the shadow being terminated in F. And from the point 1, as a centre, and at the distance 1.5, describe the arc of a circle 5.10.11. cutting the lines 1.6 1.7: in the points 10,11, from which drop perpendiculars upon 1, as 10.8: and 11.9,

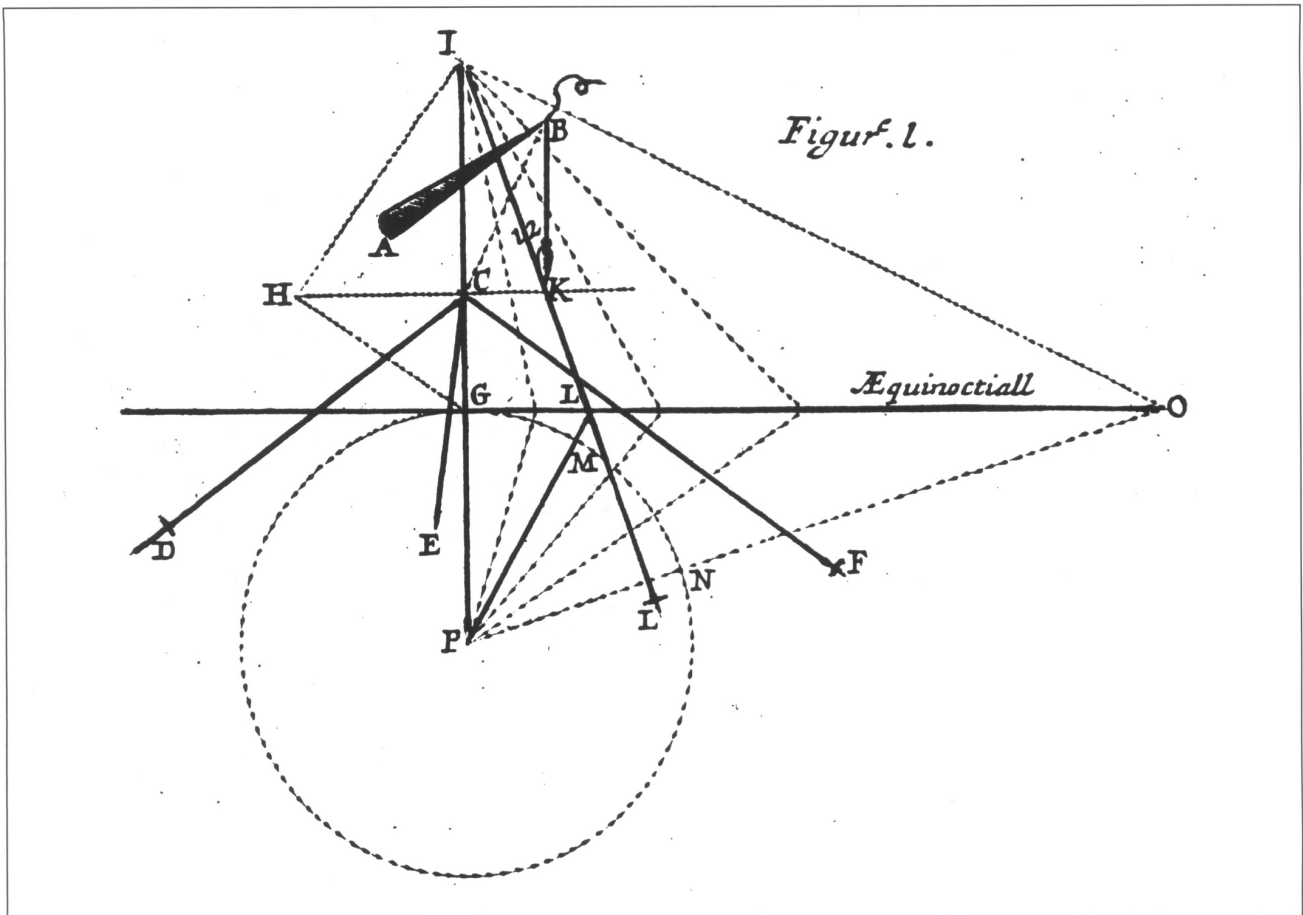

Fig.1.

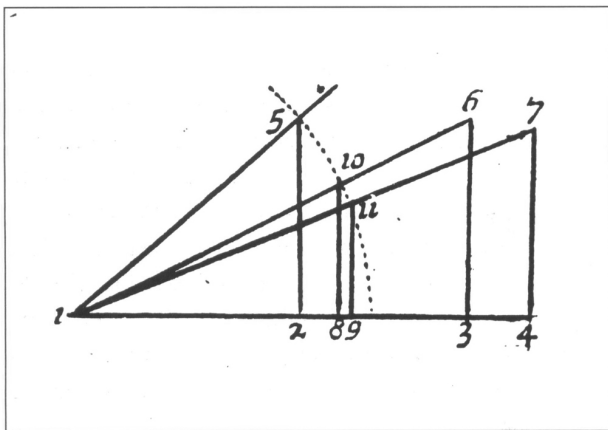

Fig.2.

Then coming to Fig 3; upon another plane, as a  $mno$ , take the point  $a$  and from it draw the three lines  $dao$ ,  $c an$ , and  $b a m$ , making amongst themselves angles equal to those made by the Lines  $CF$ ,  $CE$ ,  $CD$ ; in Fig 1, each to his own, and on the same side, viz  $oan$ , equal to  $FCE$ , and  $narn$  equal to  $ECD$ , as the third figure shows; and these lines being extended on the contrary side, as  $oa$ , as far as  $d$ , and making  $ad$  equal to 1.9: which is the difference between 1 and the point where the perpendicular falls on the point marked in the line 1,7 by the arc of a circle 5,10,11 in figure 2; for as much as 1.4 represents or resembles  $CF$ , (Fig 1)

and  $CF$  resembles  $ao$ , similarly make  $ab$  equal to 1,8 (fig 2) because as 1,4 (fig 2) resembles  $CF$  (Fig 1), and  $CF$  resembles  $ao$  (Fig 3), similarly  $ab$  is equal to 1.8 (fig 2) because 10.8 is made the length 1.3: which is equal to  $CD$  (Fig 1) and  $CD$  of the same situation or disposition as  $am$ , For the same reason make  $ac$  equal to 1.2 and draw the straight lines  $cd$ ,  $cb$ , as long as necessary; and on them in point  $c$  raise  $ce$  and  $cf$ , perpendicular both equal to  $BC$  (Fig 1) and at the point  $d$  let  $dg$  be raised perpendicular to  $cd$  and equal to perpendicular 10,8 (Fig 2) because  $ad$  is equal to 1,8. Similarly on the point  $b$  raise the perpendicular  $bb$  on the line  $cd$ , equal to 11,9 Fig 2, and drawing the lines  $cgi$ ,  $fhk$ , cutting  $ced$ ,  $cb$ , in  $I$  and  $K$ ., And if the line  $IK$  is drawn, it will give the place of the equinoctial line in relation to the lines  $oad$ ,  $nac$ ,  $mab$ ; and making  $el$  perpendicular to  $IK$  will give the meridian line on the plane represented by the lines  $oad$ ,  $nac$ ,  $mab$ .

This done, make the angle  $GCE$  (Fig 1) equal to the angle  $ack$  (Fig 3) and draw-ing  $GCI$  the meridian of the plane, then make  $GC$  (Fig 1) equal to  $cl$  (Fig 3) and drawing  $CH$  perpendicular to  $CI$  and equal to the height of the style, draw  $HG$ . Let  $HI$  be made perpendicular to  $HG$ , cutting  $GC$  in  $I$ , then the point  $I$  will be the centre of the dial. Moreover, let  $GO$  be drawn at right angles with  $GC$ , which



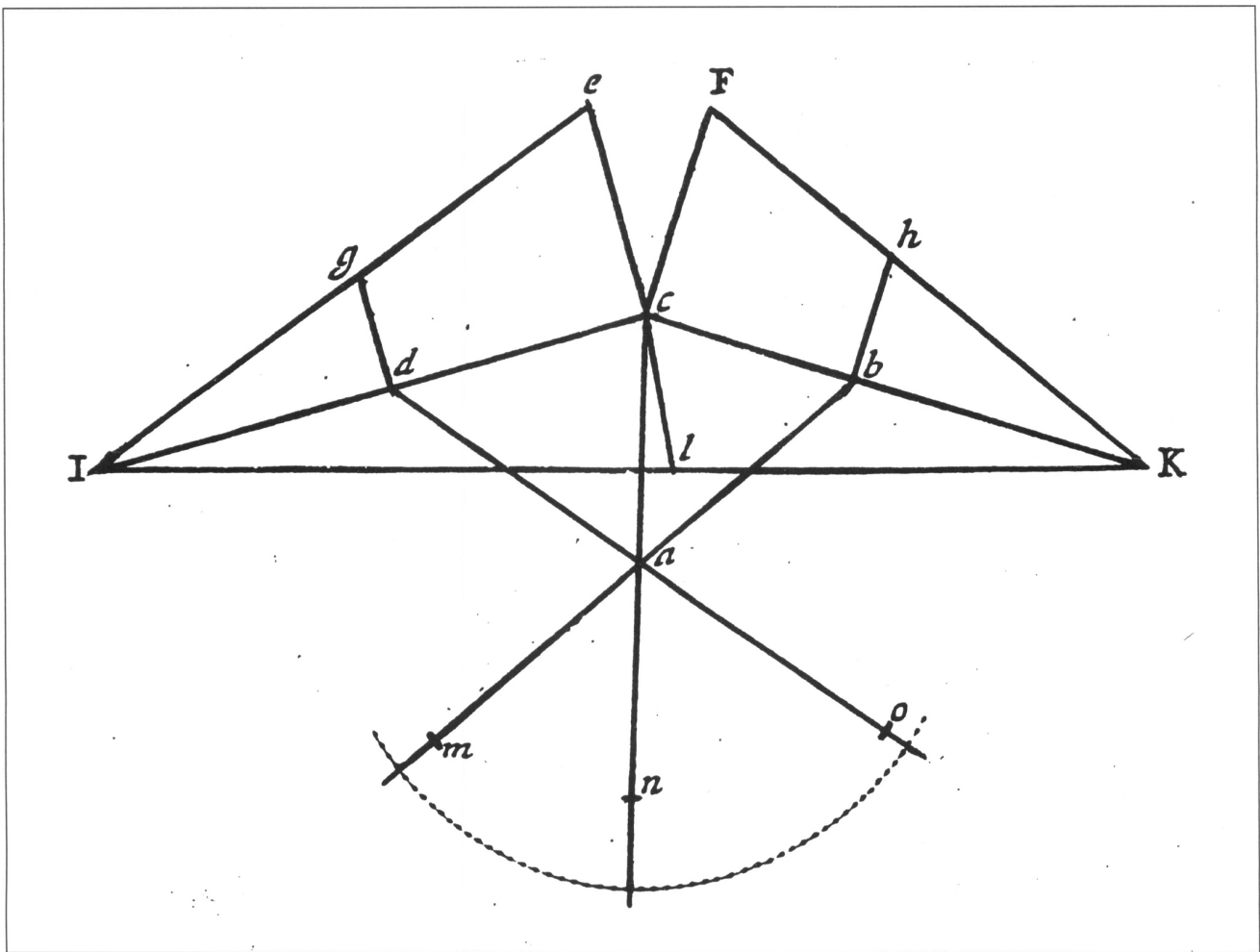

Fig.3.

will be equinoctial; and let GP be made equal to GH and from the point P as centre, and at the distance PG, describe the circle GMN which will represent the equinoctial.

**TO FINISH THE DIAL**

The meridian of the place must be found, which will be done if from the point B, (the end or top of the style) a thread be allowed to fall with a plummet sharp-ened at the end (plumb line), until its point touches the plane, as shown here at point K (Fig 1), by which from point I, drawing a straight line IKL will represent the meridian of the place; and if the plane be vertical, that is per-pendicular to the horizon, which is easily found by applying a plumb line to the plane, for if it grazes the plane, then the plane is vertical. To find the meri-dian is but to apply the end of the thread to I, the centre of the dial, and letting the plumb line hang freely, draw a straight line by the thread, which is the meridian-line of the place, Finally, produce IK, the meridian until it cuts the Equinoctial at point L, to which, from the point P, draw a straight line PL, cutting the circle GMN in M, and that line will represent the equinoctial, the line at 12 o'clock of the place for which the dial is made. Divide the circle into 24 equal parts, starting at point M,

and from the point P, from each of the divisions draw lines to the equinoctial, and from the centre of the dial I, draw lines to those points in the equinoctial, to form the hour-lines of the dial, which hour-lines number to correspond to that of the lines drawn from P to the point of the equinoctial line by which it passes, (as for example) drawing a straight line from P to N, which is the third division after M (supposing M to be on the east), this will be the three o'clock line which cuts the equinoctial at O, drawing IO will be the three o'clock line of the dial; and doing so for the rest, the dial is finished, in which the hours shall be shown by the shadow of the top of the style only.

It is to be noted that in all dials, the morning hours should be marked on the west side, and the evening hours on the east (northern hemisphere only),

**TO EXPLAIN FURTHER ABOUT FINDING THE MERIDIAN-LINE OF THE PLACE, BY A RULER, WITH A PLUMB LINE**

In Fig 4, let the Style be AB, the centre of the Dial D, from B drop a plumb line, if the thread joined to B falls outside the plane, the ruler ID must be adjusted so that at one

contact or side thereof, [it] should both touch the centre of the dial at D and the top of the style B; then find a point of the ruler from which dropping the plumb line meets the plane, at that point is the meridian of the place, and drawing from the centre of the dial D, by that point a straight line, that line shall be the meridian of the place; but if the point in which the plumb line touches the plane be so close to the centre that it is difficult to draw the line accurately, then do thus:

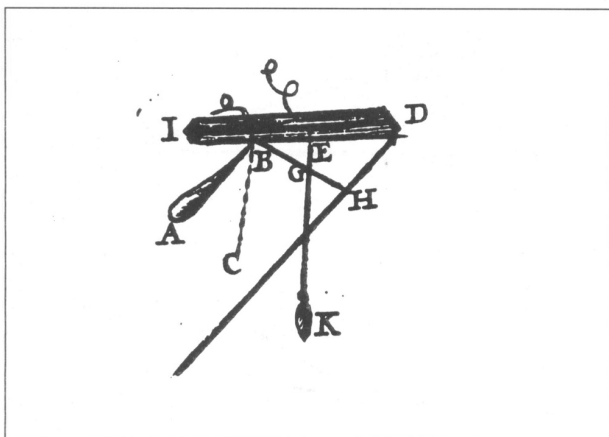

Fig.4.

Take a point at pleasure in the side of the ruler as at E, to which apply the plumb line, take another thread, fixing one of the ends to point B, and extending the other towards the plane in such a way that it cuts the plumb line perp-

endicularly; the point of meeting of the two threads, being the point to which the thread extended from B, will meet the plane as at H, will be the meridian, and drawing DH, is found,

All the difficulties which may arise in describing such a dial by three shadows are not discussed here, eg when the centre of the dial is not in the plane, nor when the meridian of the place cannot be placed there, because the solution of these difficulties would require a complete gnomonist.

It may be observed from the construction in Fig 3 that if *bcd* be in a straight line, it is the Equinoctial of the plane, and that it is a Polar plane; and if the plane be vertical, its meridian line will be that of six o'clock at that place, ie in the oriental or east side, six in the morning; and six o'clock at night in the west face. The height of the style is for the semi-diameter of the equinoctial as BC, in the first figure, but the hour-lines of the place, instead of meeting at point I, the centre, are all parallel lines.

*Note from C.K.Aked: The above is not a literal transcription, but has been designed to make Leybourn's text easier to read and understand; the original is quite difficult to the modern reader with its idiosyncratic presentation of the time and unfamiliar terms. The diagrams are reproduced without alteration although Fig 4 is not particularly clear.*

## THE DIALS AT ST MARY'S, ELMLEY CASTLE, WORCESTERSHIRE

A. O. WOOD

The pair of multiple dials in the churchyard of St Mary's Elmley Castle are well known, it is surprising that so far no account of them has appeared in the Bulletin. Indeed my 1997 recording is the only one of modern times (8 a.u.c.)\*, David Young's earlier record dates from well back in a previous millennium. (ref.1).

Elmley Castle is the name of the village. I think the castle is long gone but the church, pub and village green remain.

The larger dial (no.1), some eight or nine feet tall, stands to the left of the approach path to the church door and it is easy in one's excitement to overlook the other dial some way to the east in the churchyard. Both dials date from the mid-16th century and were erected by the Savage family whose extensive marble memorial is in the north transept of the church. (ref. 2).

In construction they are both essentially a 'diallist's conceit' and comprise a multiplicity of vertical dials facing the cardinal points and the four intermediate directions. Additionally there are many 'scaphe' dials, hemispherical hollows crossed by a gnomon, again on all faces. Reclining dials are not forgotten and there are several on the smaller dial (no. 2). The larger dial has an equatorial dial on top with gnomon pointing at the Pole Star whilst on its south side is a polar dial with its shadow plane and gnomon at 52° to the horizontal. Also deep 'recess' dials appear on both. The whole assemblies are shown in Figures 1 (larger dial, no.1) and 2 (smaller dial, no.2).

'How many dials altogether?' you may well ask. Dial no. 2 has 16 enumerated dials on three faces, as listed in ref. 4. With another four or so on the remaining face, and at least a dozen on dial no.1, we have over 30.



Fig.1.

It is heartening to report that all the metal gnomons but one are in position, none having gone astray in the last six years. The current gnomons are relatively recent and the latest item in a succession of changes of fortune over the centuries. The record in Gatty (ref. 3) suggests that the larger dial is now taller by being raised on blocks matching its cross section of 22½ inches (half an ell, ancient measure of length). Again the smaller dial has been moved, probably raised, and has suffered the loss of its top finial.

The 'recent' gnomons were installed in 1971 by S H Grylls, Chief Engineer of Rolls-Royce Motors. He extracted the old remnants from their lead settings and discovered what he described as a 'fir tree root' design making them difficult to remove. (ref. 4). The new gnomons were made in some variety of metals: 'architectural metal', copper and 'Cor-Ten' steel which acquires a protective rust of 'a nice gold colour'. He also installed the top equatorial dial mentioned on dial no. 1 and tidied up the delineations, noting along the way that all the gnomon root setting angles were correct.

The extracted gnomon remains are now on display in the church north transept with explanatory notes.



Fig.2

In the course of time the Grylls family left Elmley Castle and the Parish Council decided that the Society would be a suitable body to maintain watch on the dials and advise on conservation if necessary. To this end, all the documents relating to the Grylls involvement were handed over to John Davis who holds them on our behalf and has a 'watching brief'. Fortunately the dials seem robust enough and apart from some heavy lichen or other plant life on the smaller one they are in good shape.

There are two other items of sundial interest at Elmley Castle. On the west quoin of the south wall of St Mary's is what may be a 'dial' of some sort. It seems likely to be a noon marker and is of a recessed hollow type possibly akin to those on the Savage dials.

On the 'village green' at the lower end of the road up to the church is an old column with a stone on top. If you look very closely the remnants of a gnomon are apparent on one face but the main interest is the vertical (sideways) inscription on the column of 'ADOM MCXLVII' i.e. Anno DOMini 1147. The column is quite a remarkable survival, and it has been put to good use in the past to carry the village sundial for many years no doubt.(Fig. 3).

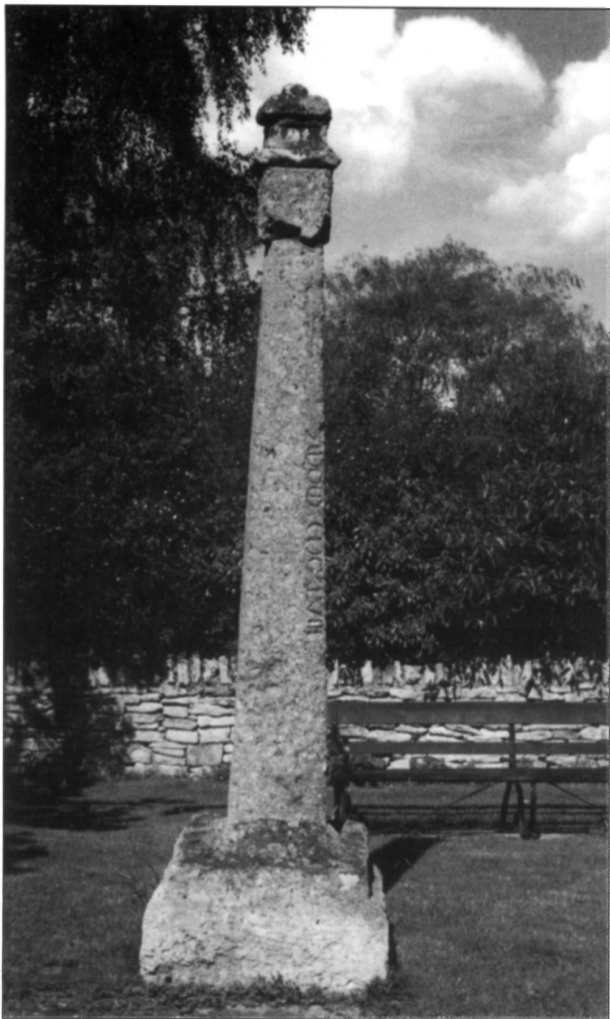

Fig.3.

\* a.u.c. 'from the foundation of the learned society'

**REFERENCES:**

- 1) British Sundial Society Register 2000.  
SRNo 0491 - Savage dial no. 1, SRNo 0490 - Savage dial no .2  
SRNo 3689 - village green dial
- 2) St Mary's Church, Elmley Castle, Official Guide (a model of its kind!)
- 3) M Gatty and E Lloyd, The Book of Sundials, pub. George Bell, 1889
- 4) S H Grylls, Elmley Castle Sundials, Vale of Evesham Historical Research Papers, Vol IV (1973)

*A.O.Wood  
Gloucester*

**COUNCIL OF THE BRITISH SUNDIAL SOCIETY 18 OCTOBER 2002**

Back Row, L to R: Tony Wood, Doug Bateman, Patrick Powers, Kevin Barrett.

Front Row, L to R: Gerald Stancey, Christopher Daniel, Graham Aldred, Margaret Stanier.



## THE RT. HON. THE EARL OF PERTH P.C. (1907-2002)

Patron of the British Sundial Society

On Monday, 25 November 2002, John David Drummond, 17th Earl of Perth, died in Perth at the age of 95 years. Sworn of the Privy Council in 1957, he was also 20th Lord Drummond of Cargill and Stobhall, 17th Lord Maderty, Hereditary Thane of Lennox and Hereditary Steward of Menteith and Strathearn. A kind and generous man, much admired and respected, Lord Perth was a banker, government minister and a patron of the arts. He was a trustee of the National Museums of Scotland and of the National Library of Scotland, a member of the Court of St Andrew's University, a Fellow of the Royal Incorporation of Architects of Scotland and a Fellow of the Society of Antiquaries of Scotland. He was Patron of the British Sundial Society from its inception in 1989.

Born on 13 May 1907 in London, John David Drummond was the son of Sir Eric Drummond, who had been the first Secretary-General of the League of Nations and who succeeded as the 16th Earl of Perth and 12th Viscount Strathallan on the death of his half-brother in 1937. In view of his father's diplomatic duties, David Drummond was brought up by his aunt, the Duchess of Norfolk, in the magnificent surroundings of Arundel Castle in Sussex. A devout Catholic throughout his life, he was educated at Downside and Trinity College, Cambridge.

On leaving university, David embarked on a career in the City of London, joining J. Henry Schroder, the merchant bankers. At the outbreak of World War II and now in his early thirties, David joined the Intelligence Corps and was sent to Paris to report on the state of the French army, on troop movements and also, evidently, to help Noel Coward run a propaganda office. Almost as the advancing German army entered Paris, so the story goes, he commandeered a large Bentley and, with Noel Coward as a passenger, drove out of the city, escaping only just in time!

After the fall of France, David was sent to the United States to sound out American feeling about the war. In the circumstances, a better 'ambassador' could not have been chosen for such a mission, since, in 1934, David had married an American, Nancy Seymour Fincke, the daughter of Reginald Fincke of New York. Undoubtedly, she had a charming and lively life-long influence on her husband and his career.

In 1942, on his return from the USA, David was seconded to the War Cabinet Office and later worked in the Ministry of Production, until the return of peace, when he rejoined Schrodgers, becoming a director in 1946. It was largely due to his energy and drive that, by the mid-Fifties, Schrodgers had once more become established as a major financial institution in the City.

In 1951, David succeeded to the Earldom and was elected a Scottish representative peer. In 1956, just when he had been appointed president of the bank, he was offered a government post by the then Prime Minister, Sir Anthony Eden, as Minister of State at the Colonial Office. By the time Perth had assumed office, Eden had been succeeded by Harold Macmillan. The six years that followed, in the aftermath of the Suez crisis, were turbulent times for the government and certainly for Lord Perth. He found himself involved in huge social and economic problems throughout Africa, during a time of great change (reflected in Macmillan's historic speech of 5 February 1960 in Cape Town, when he referred to "...a wind of change blowing throughout the continent of Africa") when his diplomatic skills must have been tested almost to their limits. He recognised the fact that the process of such change would take time; but time was not on his side or on that of the government.



*Lord Perth beside one of the sundials in the Stobhall garden.*

In 1962, Harold Macmillan drastically reorganised his government and Perth was obliged to leave office. Nevertheless, on leaving the government, he was invited to become the First Commissioner of the Crown Estates, the largest landowners in the United Kingdom, which, at least, must have been in recognition of his valuable and loyal service. The appointment called for the supervision of the revenue from all the various properties concerned, a task which Perth took up with his usual enthusiasm and which he fulfilled with vigour, as well as considerable professional financial skill.



*Lord Perth with a BSS member during the Society's visit to Stobhall, June 2000.*

Lord Perth was born into a family that, according to tradition, could trace its descent from a Drummond who had arrived in Scotland from Hungary in the 11th century. In 1488, a Drummond was the Constable of Stirling Castle and also became a Lord of Parliament. The Earldom of Perth, however, was created for the 4th Lord Drummond in 1605. The Viscounty of Strathallan was created in 1686. The Perth and Strathallan peerages were united in the 20th century, when the 11th Viscount Strathallan succeeded his kinsman, the 14th Earl of Perth, in 1902.

Although born and brought up in England, Lord Perth had always set his heart on having his home in Scotland. In 1954, a distant relative, the Earl of Ancaster, offered him Stobhall by Perth, a partially ruined 15th century castle, which had been the original family stronghold. Perth could not resist the offer and he and his wife, Nancy, set about the daunting task of restoration, with all the enthusiasm, energy and drive that were the hall-marks of the Perth family. With love, care and attention to detail, the Earl and Countess of Perth made Stobhall not only a warm, friendly family home, but one of Scotland's most attractive small castles. Lord Perth built an adjoining library for his books, and created a garden, in which he installed a number of fine historic sundials that he had collected. It is understood that, at some time in his earlier years, he constructed one of the sundials himself



*A sundial at Stobhall, thought to have been designed by Lord Perth.*

It was through the knowledge of the sundials at Stobhall that Dr Andrew Somerville, who later became the Society's first chairman, got to know Lord Perth and it was through this connection that the 17th Earl of Perth came to be the first Patron of the British Sundial Society. It is well known that he took a great interest in the Society, attending the annual conference dinner in Edinburgh and coming down to West Dean to present the first of the awards, in the Society's Award Scheme. He also received members of the Society at his home on a number of occasions. He endeavoured to save a rare and valuable 17th century sundial for the Nation from auction sale abroad, and he was responsible for encouraging the National Museum of Scotland to have a sundial carved into the stonework of their new building in Edinburgh. Undoubtedly, with his interest in sundials, the Earl of Perth could not have been a better first Patron of the British Sundial Society.

The Earl of Perth's wife, Nancy, died in 1996. He is survived by their two sons, the elder of whom, Viscount Strathallan, becomes the 18th Earl of Perth.

*Christopher St J H Daniel*

# HONORARY OFFICIALS OF THE BRITISH SUNDIAL SOCIETY

*President:* Sir Francis Graham-Smith F.R.S.

*Vice-President:* Mr. David A Young

## COUNCIL MEMBERS

Mr. C.St.J.H. Daniel (Chairman)  
8 The Maltings, Abbey Street  
FAVERSHAM  
Kent ME13 7DU  
Tel: 01795 531804  
chris.daniel@  
btinternet.com

Mr. D.A. Bateman (Secretary)  
4 New Wokingham Road  
CROWTHORNE  
Berkshire RG45 7NR  
Tel: 01344 772303  
douglas.bateman  
@btinternet.com

Mr. Gerald P. Stancey (Treasurer)  
22 Peterborough Avenue  
OAKHAM  
Rutland LE15 6EB  
Tel: 01572 756444

Mr. K Barrett (Membership Secretary)  
108 Brondesbury Road  
QUEEN'S PARK  
London NW6 6RX  
Tel: 020 7625 2921  
sundial@dial.pipex.com

Mr. P. Powers (Registrar)  
16 Moreton Avenue  
HARPENDEN  
Hertfordshire AL5 2ET  
Tel: 01582 713721  
patrick\_powers@  
compuserve.com

Dr. M.W. Stanier (Editor)  
70 High Street  
SWAFFHAM PRIOR  
Cambridgeshire  
CB5 0LD  
Tel: 01638 741328  
margaret@mstanier.  
fsnet.co.uk

Mr. Graham Aldred (Librarian & Restoration)  
4 Sheardhall Avenue  
Disley, STOCKPORT  
Cheshire SK12 2DE  
Tel: 01663 762415  
graham.aldred@  
iclway.co.uk

Mr. A. O. Wood (Mass Dials)  
5 Leacey Court  
CHURCHDOWN  
Gloucestershire GL3 1LA  
Tel: 01452 712953  
aowood@soft-data.net

## SPECIALISTS

Mr M. Cowham (Advertising)  
PO BOX 970  
HASLINGFIELD  
Cambridgeshire  
CB3 7FL  
Tel: 01223 262684  
mike@eastlands99  
freeserve.co.uk

Miss R.J. Wilson (Biographical Projects)  
Hart Croft  
14 Pear Tree Close  
CHIPPING CAMPDEN  
Gloucestershire GL55 6DB  
Tel: 01386 841007  
jill.wilson@  
ukonline.co.uk

Miss M. Lovatt (Sales)  
5 Parndon Mill  
HARLOW  
Essex CM20 2HP  
Tel: 01279 452974  
mlovatt@pavilion.co.uk

Mr. D.A. Young (Exhibitions and Acting Archivist)  
Brook Cottage  
112 Whitehall Road  
CHINGFORD  
London E4 6DW  
Tel: 0208 529 4880  
davidsun@lineone.net

Mr. Peter K. Scott (Webmaster)  
67 Lever Park Avenue  
HORWICH  
Near Bolton  
Lancashire BL6 7LQ  
Tel: 01204 693746  
bss@exford.co.uk

Mr. P. Nicholson (Internet Advisor)  
9 Lynwood Avenue  
EPSOM, Surrey  
KT7 4LQ  
Tel: 01372 725742  
piersn@aol.com

